



CATIA V5 Training
Foils

Student Notes:

**CATIA Tools for
Proficient Users**

Version 5 Release 19
September 2008

EDU_CAT_EN_PRO_FF_V5R19

About this course

Objectives of the course

Upon completion of this course you will be able to:

- Create and reuse advanced replication tools like Power Copies
- Store components and Power copies into catalog and reuse them in a new context
- Analyze and convert CATIA V4 models to CATIA V5.

Targeted audience

Advanced Users

Prerequisites

Students attending this course should have knowledge of CATIA BASICS and Part Design



Student Notes:

Table of Contents (1/2)

■ Creating and Using Power Copy	5
◆ Power Copy Presentation	6
◆ Creating a Power Copy	11
◆ Saving a Power Copy	17
◆ Instantiating a Power Copy	20
◆ Summary	25
■ Creating Catalogs of Components	26
◆ Catalog Workbench Presentation	27
◆ Browsing Catalogs	34
◆ Creating Catalogs	42
◆ Creating Chapters	48
◆ Creating Families	51
◆ Creating Keywords	54
◆ Creating Components	57
◆ Creating Part Family Components	60
◆ Referencing Data from External Catalogs	69
◆ Checking the Catalog Preview	75
◆ Creating Catalogs in Batch Mode	81





Student Notes:

Table of Contents (2/2)

◆ To Sum Up	85
■ From CATIA V4 to V5 Basics	86
◆ Working with a CATIA V4 Document	87
◆ To Sum Up	96
■ Course Summary	97

Creating and Using Power Copy

You will learn how to create, save, and instantiate a Power Copy.

-  **Power Copy Presentation**
-  **Creating a Power Copy**
-  **Saving a Power Copy**
-  **Instantiating a Power Copy**
-  **Summary**

Power Copy Presentation

In this lesson, you will have an overview of 'Power Copy' and the ways it can be used.

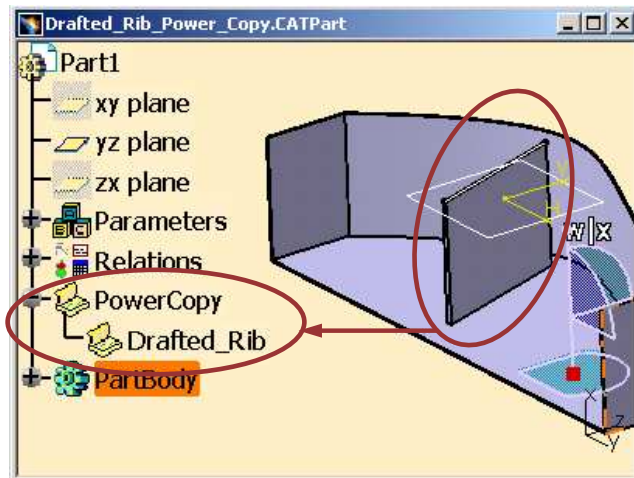

Power Copy definition

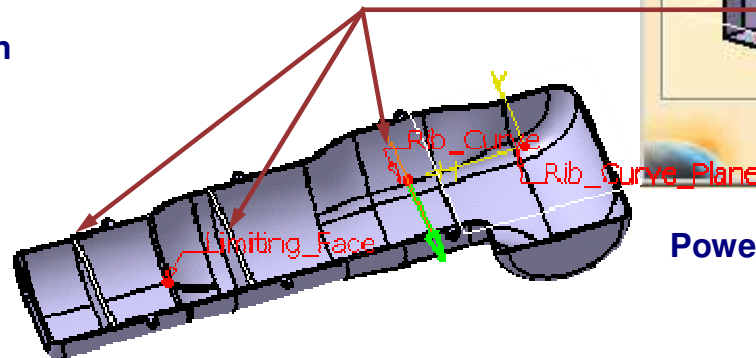
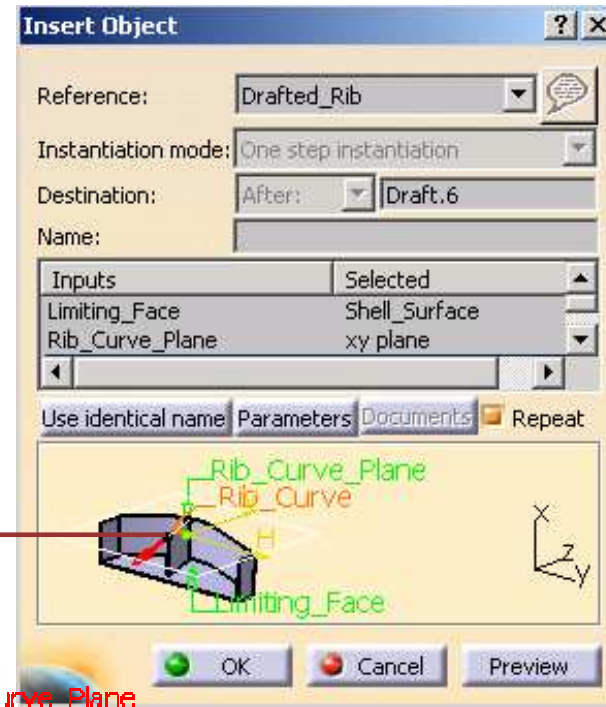

Power Copy instantiation

What is a Power Copy?

- Power Copy is a set of design features grouped together in order to be reproduced. It is a kind of advanced copying tool.
 - ◆ While defining it, you can specify the inputs that the user should provide.
 - ◆ During instantiation, you can customize it and insert it in the design of any part.

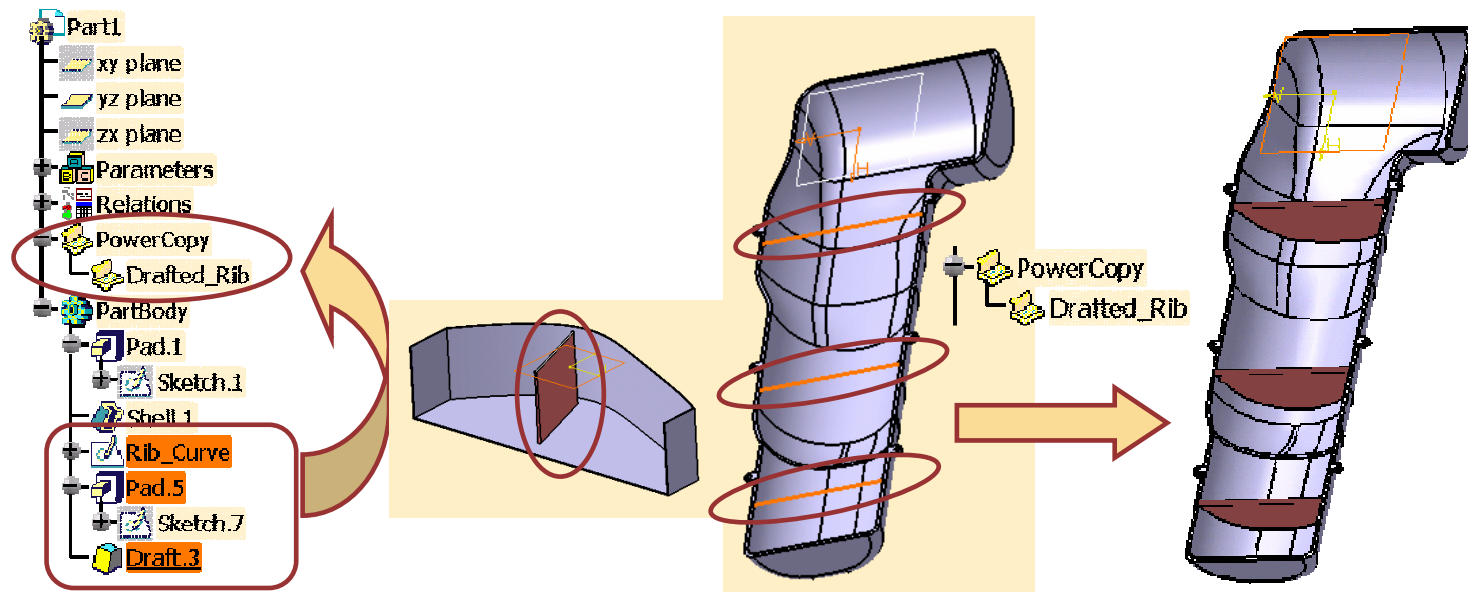

- Power Copy tools are available in the Insert menu (Advanced Replication Tools) of those workbenches:

- ◆ Part design,
- ◆ Wireframe and Surface,
- ◆ SheetMetal Design



Student Notes:

Example of Power Copy (1/3)

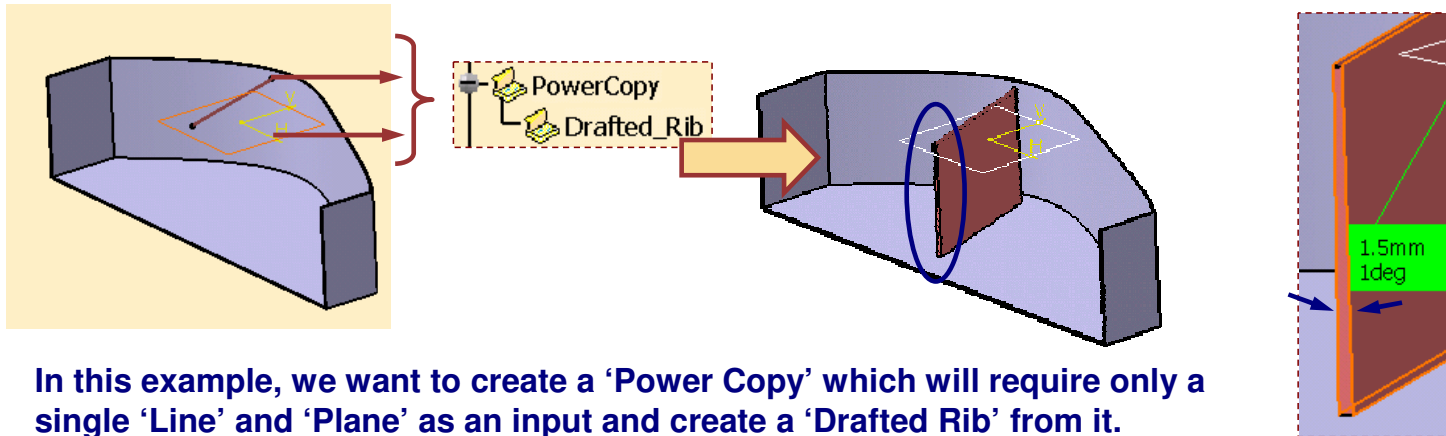

In this example, we want to create a 'Power Copy' which will require only a single 'Line' and 'Plane' as an input and create a 'Drafted Rib' from it.

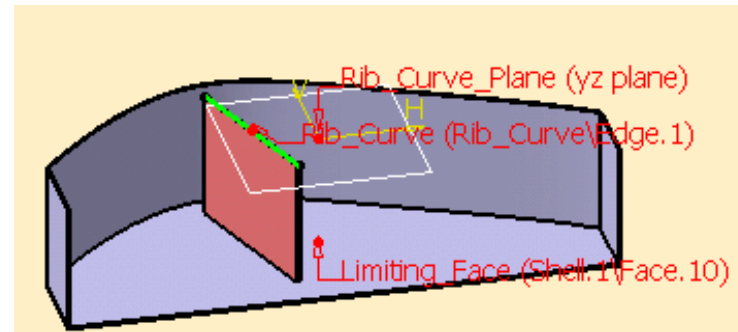
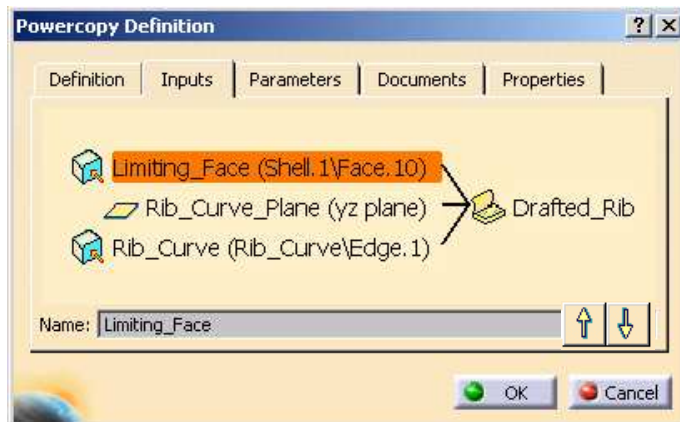

These are the inputs that the user will specify during the instantiation of the 'Power Copy'.

Example of Power Copy (2/3)

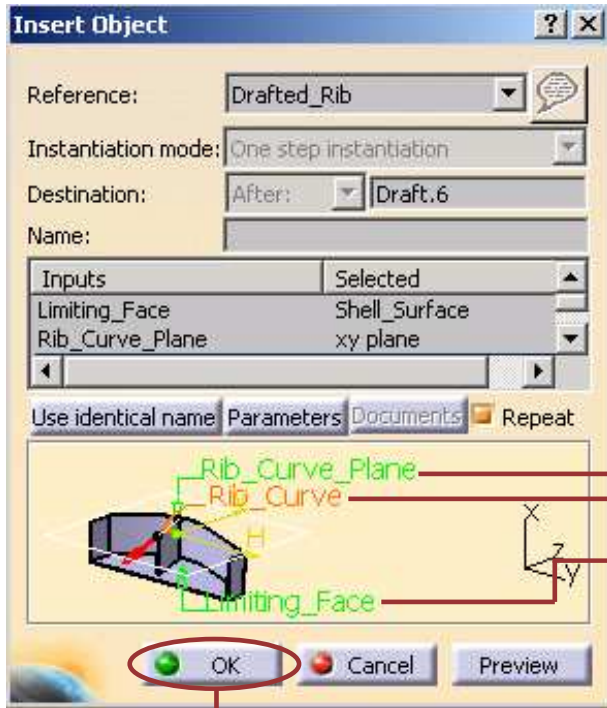

During the instantiation of the 'Power Copy', the user has to select inputs with respect to the destination part.

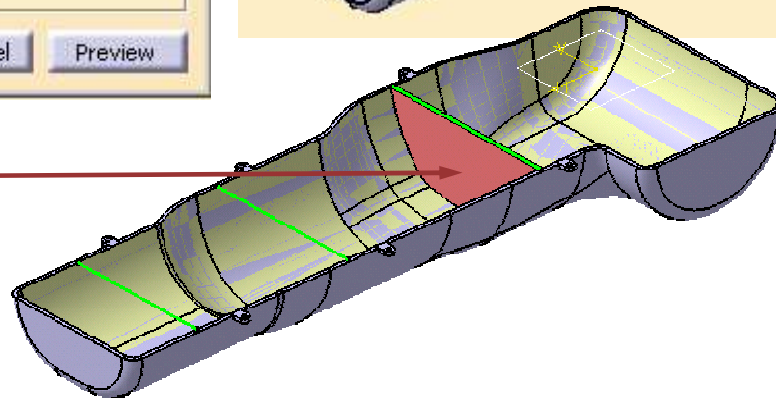
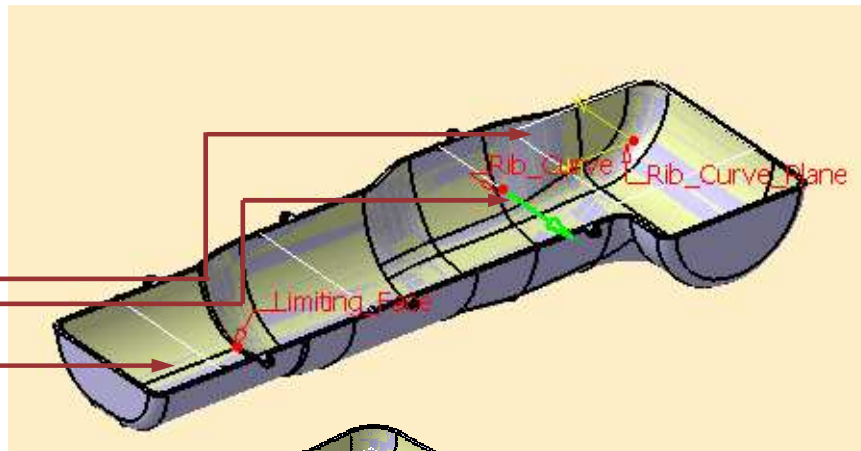

Example of Power Copy (3/3)

In this case, these are the geometries that the 'Power Copy' feature creates automatically.

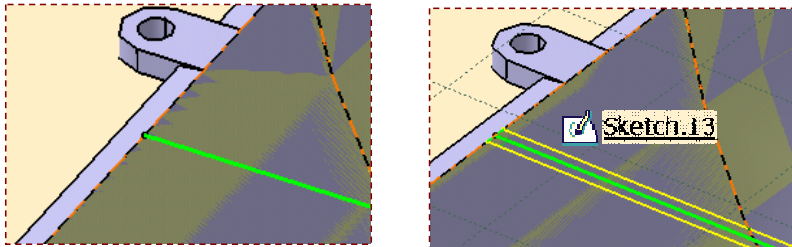

Creation of rectangular sketch from the selected rib line.

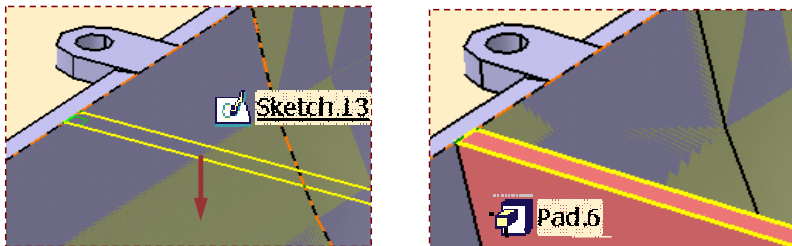

Extrusion of this sketch up to the selected 'Limiting Surface'

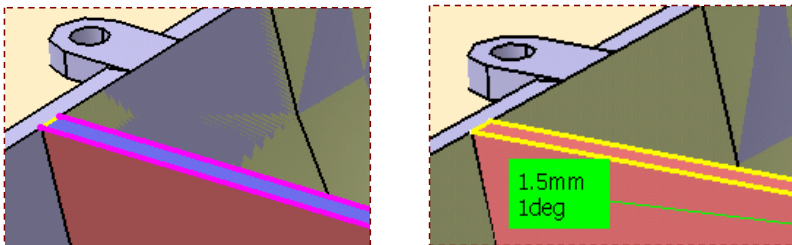

Application of 'Draft' to the extruded faces.

Thus, in this example you have seen how a power copy feature can create a 'Drafted Rib' from a single 'Line' as input.

Creating a Power Copy

You will learn to create a Power Copy.

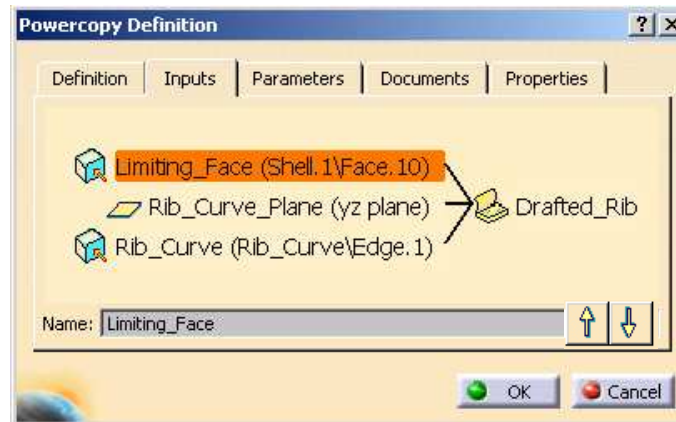
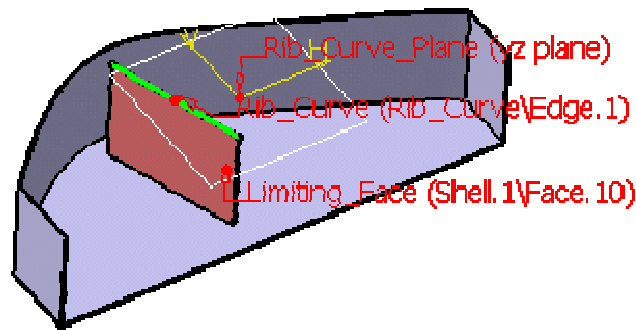
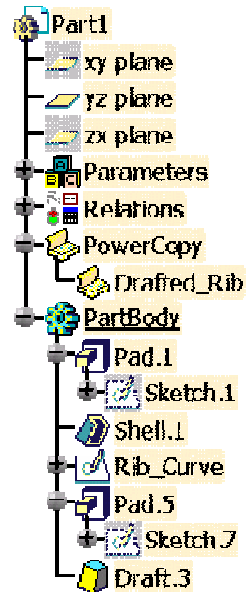

Process for Power Copy Creation

Creation of Power Copy consists of the following steps:

- 1 Making the Part ready for the creation of the Power Copy
- 2 Setting Definition
- 3 Identifying and naming inputs
- 4 Publishing Parameters
- 5 Setting Icon and preview properties

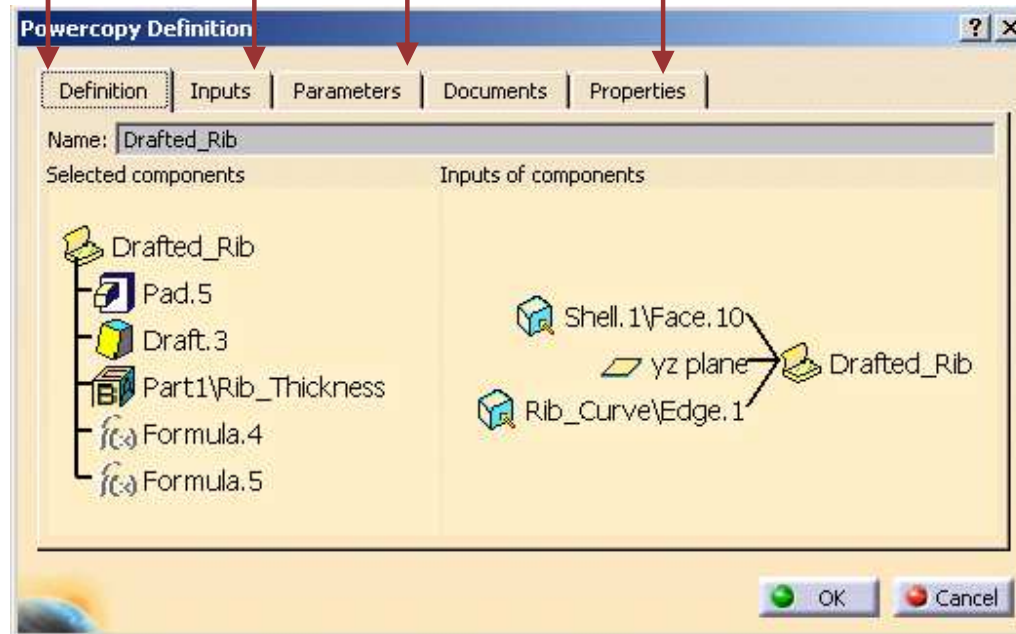
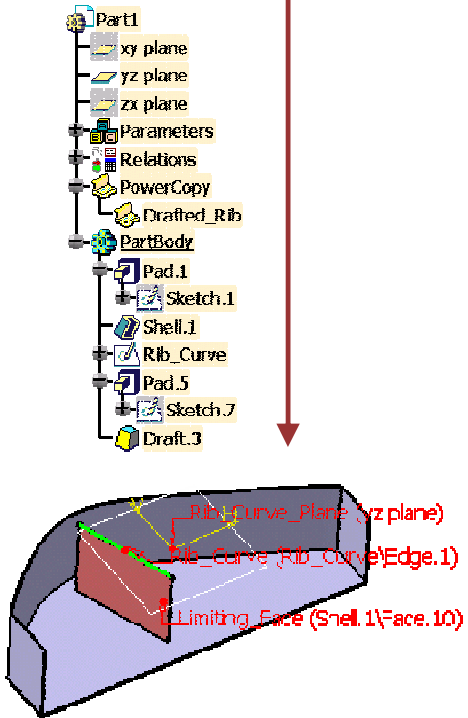

How to Create a Power Copy (1/4)

Once you have the right geometry in your CATPart, you can create the Power Copy.

- 1a Select Power Copy from the menu. (Insert > Knowledge Templates > Power Copy)
- 1b Type the name of the Power Copy in the 'Definition Tab' of the 'Powercopy Definition' dialog box.
- 1c From the specification tree, select the features that will make your 'Power Copy'.

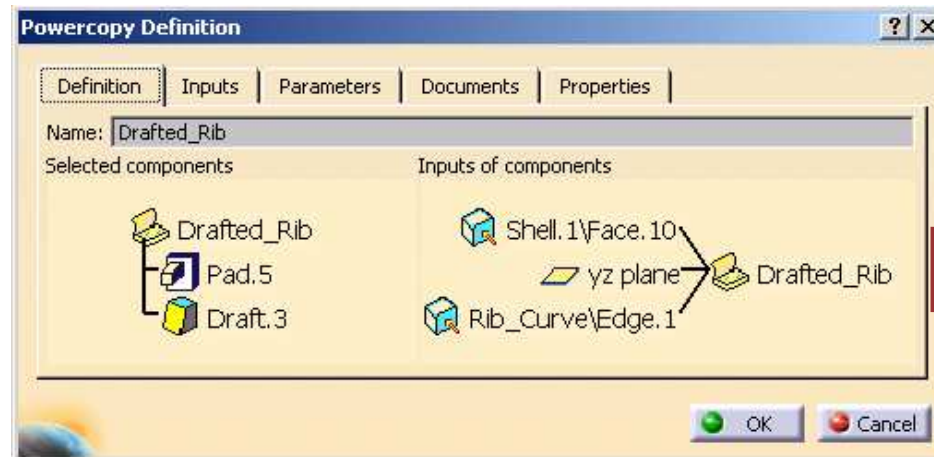
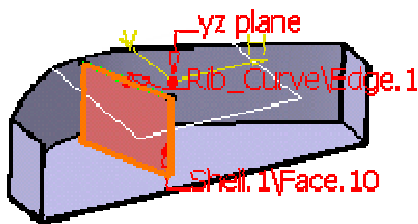
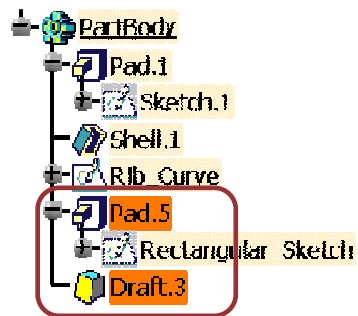
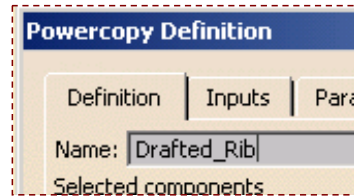

On selecting the features, the 'Inputs of components' are identified. These depend upon the features that you select to make your PowerCopy.

How to Create a Power Copy (2/4)

After selecting features making the power copy, you can give names to the geometric inputs. During instantiation, the user will be prompted to select the geometries based on these new names.

In our case there are three inputs:

- A. The edge (Edge.1) from 'Rib_Sketch' -> Using this sketch, the power copy creates the 'Rectangular Sketch'
- B. The YZ plane on which the 'Rib_Curve' has been created.
- C. The shell face (Face.10) upto which the 'Pad.5' was extruded.

Let us give new names to these inputs from instantiation point of view.

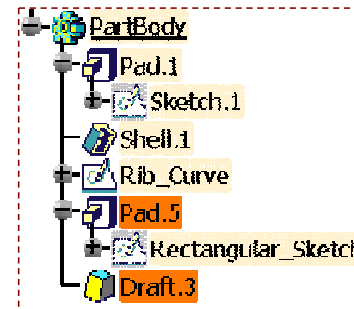

- 2a Select inputs tab
- 2b Select the input to be renamed
- 2c Type a new name for the input.

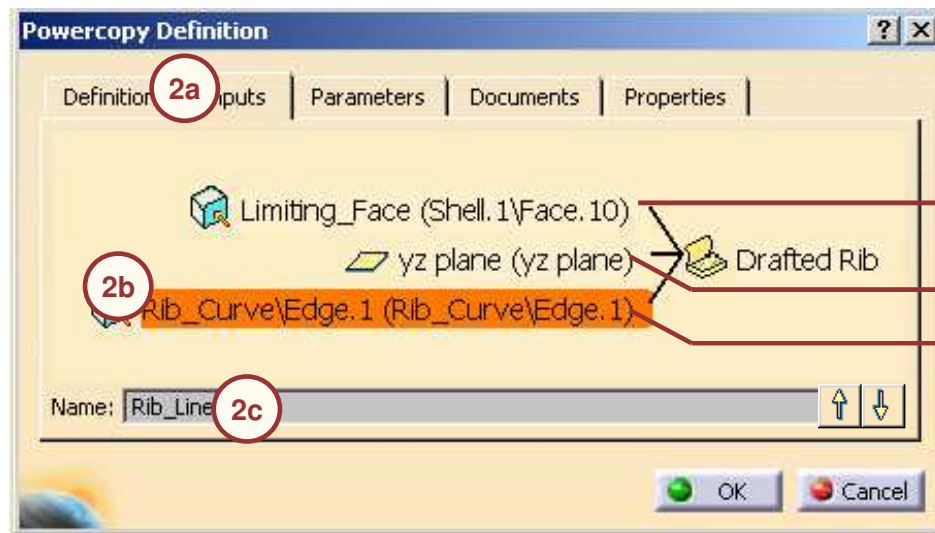

- New Name:
- Limiting_Face
- Rib_Curve_Plane
- Rib_Curve

How to Create a Power Copy (3/4)

After renaming the geometric inputs, you can publish parameters. During instantiation, the user can specify values for these published parameters.

To publish the parameters:

3a Select parameters tab

3b Select parameter

3c Check the 'Published' option

3d If necessary, rename the parameter

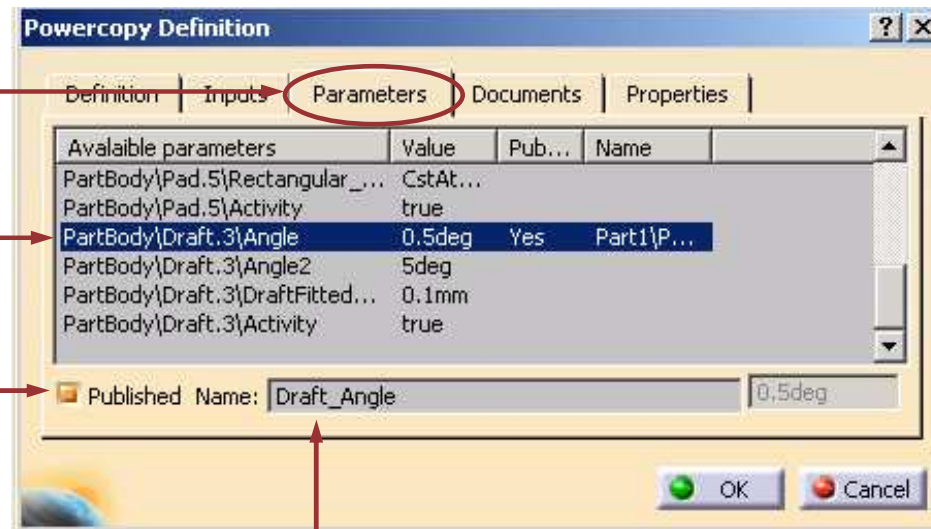

Note that it will be easier for you to recognize them if you have already renamed parameters with knowledgeware tools. [f(x)]

How to Create a Power Copy (4/4)

Once parameters are published, you can select the icon for your Power Copy and make a screen grab to create a preview of your Power Copy for catalogs.

4a Select 'Properties' tab

4b Select any icon from the available list.

4c Prepare the CATPart window for the screen grab

4d Click 'Grab screen' to make a screen grab and click OK to validate.



To prepare the screen grab, you can remove tree and compass from the window and get the correct zoom and orientation.

Student Notes:

Saving a Power Copy

You will learn to save the Power Copy in a catalog.

The diagram illustrates the process of saving a Power Copy. On the left, a CAD tree structure is shown with 'Part1' as the root. Under 'Part1', there are 'xy plane', 'yz plane', and 'zx plane'. Below these are 'Parameters', 'Relations', 'PowerCopy', 'Drafted_Rib', and 'Partbody'. 'PowerCopy' and 'Drafted_Rib' are circled in red. A red arrow points from 'Drafted_Rib' to a dashed box labeled 'Catalog Browser...'. Another red arrow points from this box to the 'Catalog Browser' window on the right. A large green arrow points from the left towards the 'PowerCopy' element.

The 'Catalog Browser' window on the right shows the following details:

- Current: 3 inputs
- Item: Drafted_Rib
- Filter: (empty)
- Launch button
- Close button

Name	Input 1	Input 2	Input 3
1 Drafted_Rib	Limiting_Face	Rib_Curve_Plane	Rib_Curve

Saving a Power Copy

If you do not save the CATPart containing the Power Copy, you will not be able to instantiate the Power Copy.

You can save the Power Copy in a new catalog and also in an existing catalog.

You can also update a catalog which makes reference to the Power Copies of your CATPart

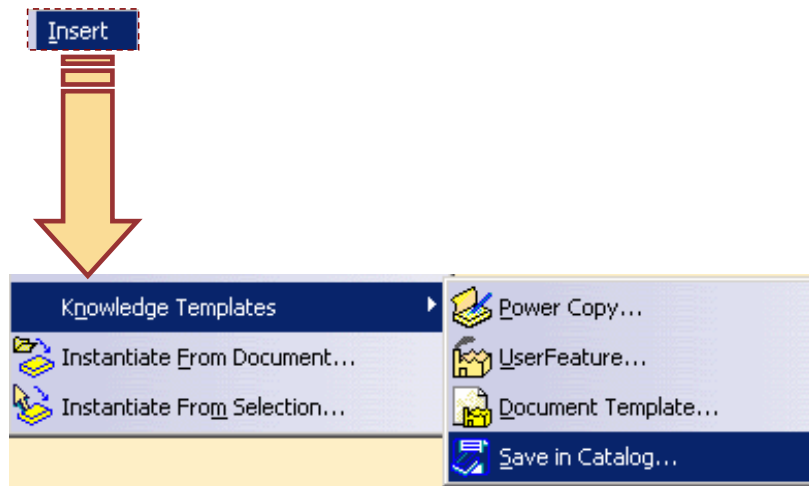

Saving a Power Copy in a Catalog

If you do not save the CATPart containing the Power Copy, you will not be able to instantiate the Power Copy.

You can save the Power Copy in a new catalog and also in an existing catalog.

You can also update a catalog which makes reference to the Power Copies of your CATPart.

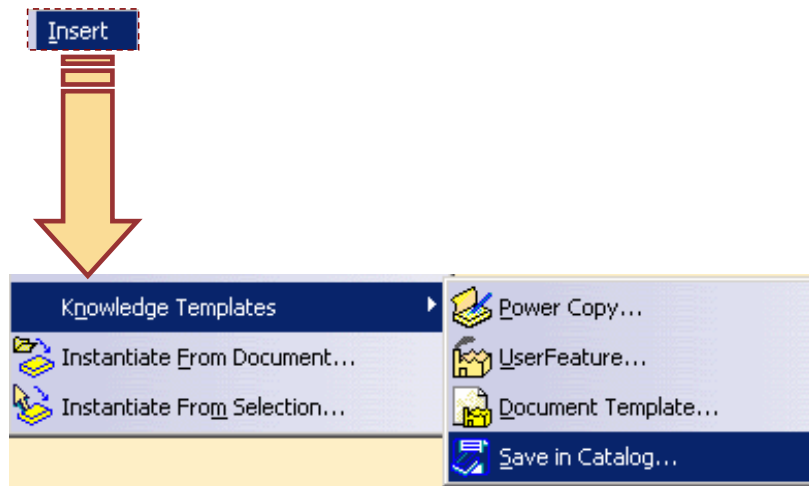

Instantiating a Power Copy

You will learn to instantiate a Power Copy differently at different places by varying geometric inputs and parameters while instantiating.

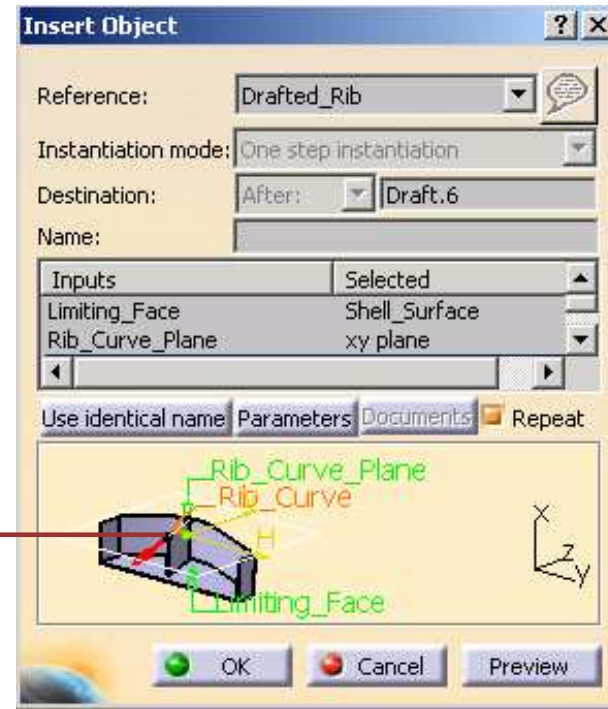
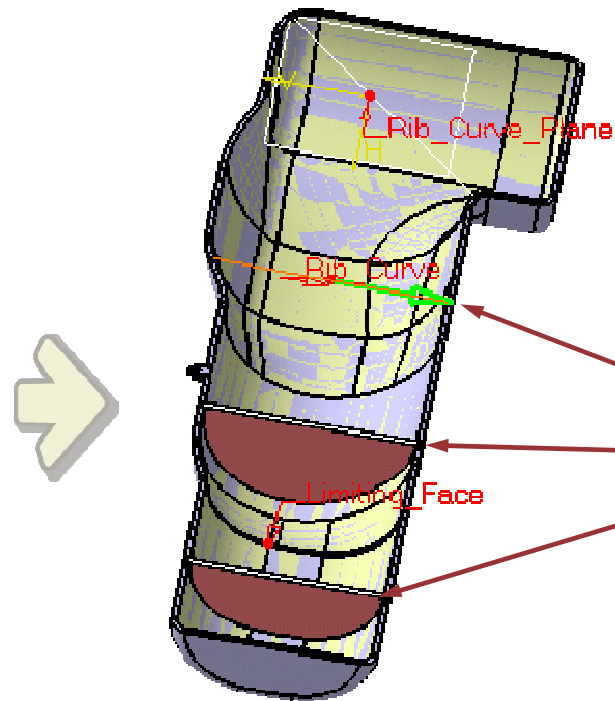

Power Copy instantiation

How to Instantiate a Power Copy (1/4)

First step of the Power Copy instantiation is accessing the Power Copy.

You can access it:

- a) From the CATPart file containing it.
- b) From a catalog having its reference.
- c) By using a VB macro (described in the CATIA documentation)

Before proceeding, please save all the CATIA documents that are attached to this screen to a local folder.

1 Open the CATPart in which you want to instantiate the Power Copy. 

2 From the menu, select:
Insert > Instantiate From Document OR

3 Select the CATPart file which contains your Power Copy. OR

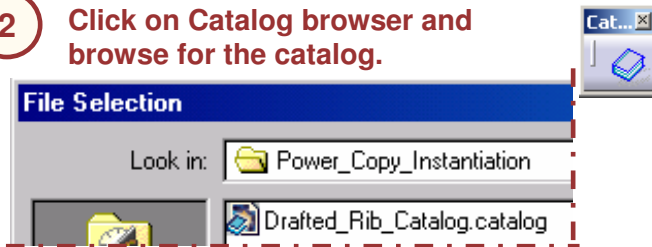
2 Click on Catalog browser and browse for the catalog. 

3 After opening the catalog, double-click on 'PowerCopy', then on '3 inputs' and finally on 'Drafterd_Rib' to open the instantiation dialog.

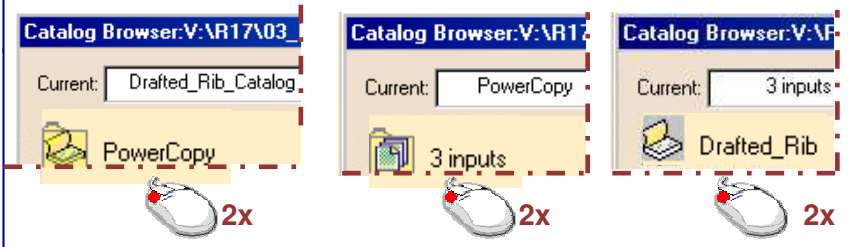
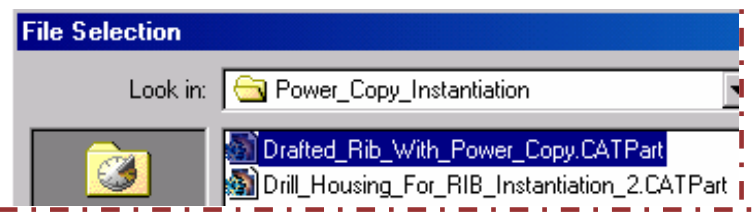

How to Instantiate a Power Copy (2/4)

Second step of the instantiation is selecting the geometric inputs of the Power Copy.

- 3a Select the geometric inputs of the PowerCopy as shown. For this example select the 'Limiting Surface' and 'Rib_Curve_Plane' as shown.

Insert Object

Reference: Drafted_Rib

Instantiation mode: One step instantiation

Destination: Alter Sketch.1

Name:

Inputs	Selected
Limiting_Face	Shell_Surface
Rib_Curve_Plane	xy plane
Rib_Curve	Edge

Use identical name Parameters Documents Repeat

OK Cancel Preview

Drill_Housing

- xy plane
- yz plane
- zx plane
- Parameters
- Relations
- PartBody
- ThickSurface.1
- Pad.5
- Sketch.12
- Sketch.1
- Geometrical Set.1
- Shell_Surface

Rib_Curve_Plane

Rib_Curve

Limiting_Face

Now the first two inputs remain the same for all the three green 'Rib_Curves'. So in this case you can use the 'Repeat' option.

- 3b Select the 'Repeat' option, select any one of the three green lines and click OK. Repeat the same process for any one of the remaining two green rib lines.

How to Instantiate a Power Copy (3/4)

You can also change the values of the parameters that you have published during the Power Copy creation.

In this example, we will enter different values for the last rib line.

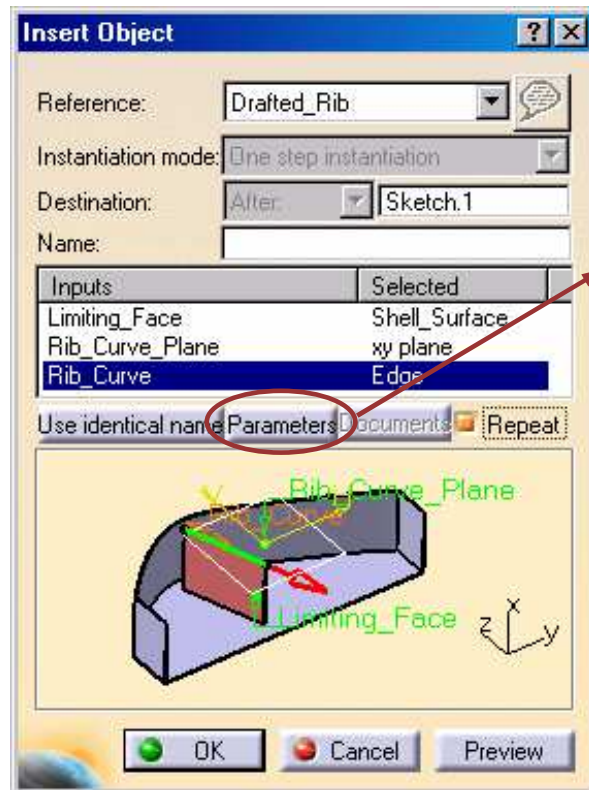

4a Select the remaining Rib_Curve and click the 'Parameters' button.

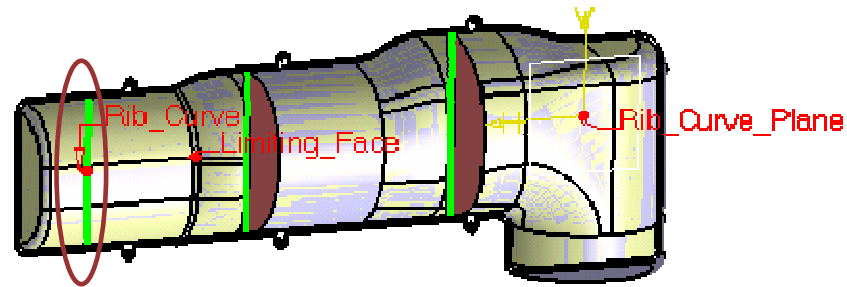

4b Enter the values for the parameters as shown and close the 'Parameters' dialog box.

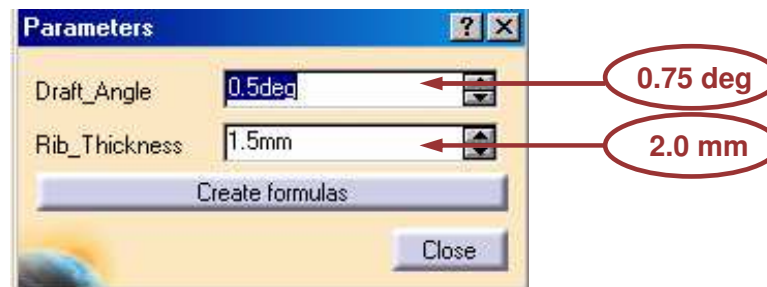

4b Click OK to the 'Insert Object' dialog box to instantiate the last rib and then click 'Cancel' to dismiss it.

How to Instantiate a Power Copy (4/4)

The result of the Power Copy instantiation is inserted after the “in work object”.

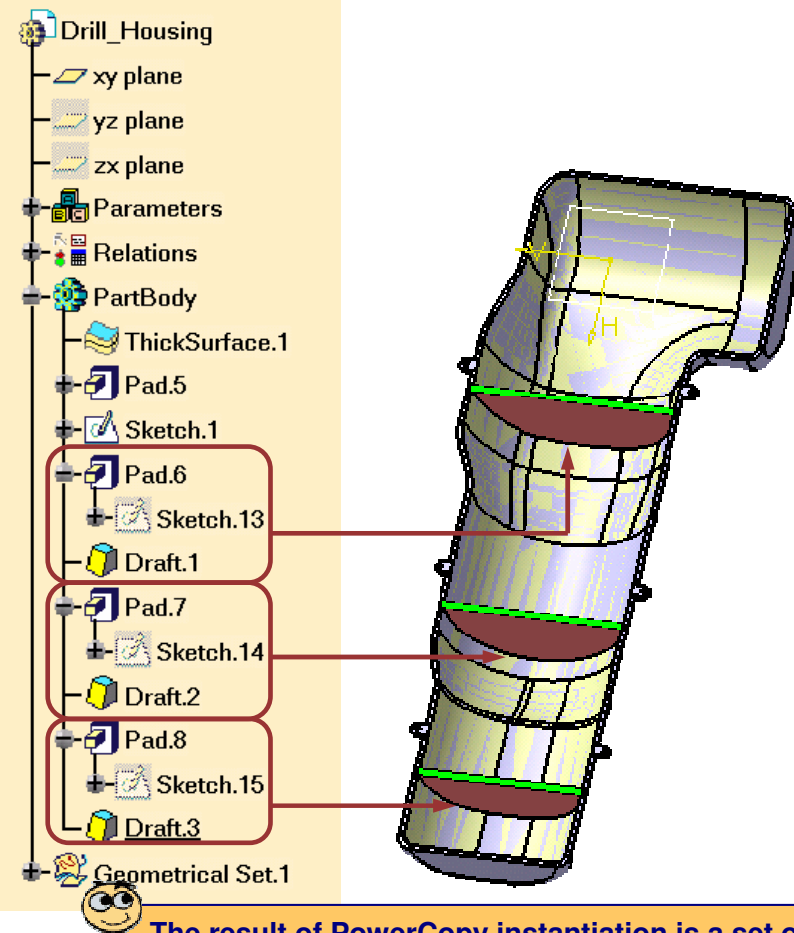

The result of PowerCopy instantiation is a set of editable features. They are not linked to the original features of the PowerCopy CATPart.

Summary

You have learned:

- **What is a Power Copy? Power Copy is a set of design features grouped together to be reproduced. It is advanced copy tool. Power Copy tools are available in Insert menu in Part design, Wireframe and surface, sheet metal design workbenches.**

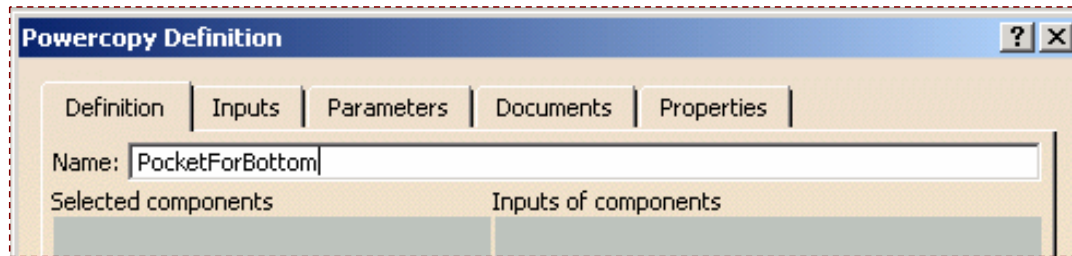

- **How to create a power copy? During creation you have to set definition, Identify and name inputs, publish parameters, select icon and preview.**
- **How to save a power copy? Saving of power copy is necessary, if not saved, power copy can never be instantiated. This can be done through Insert > Advanced replication tools > save in catalog.**
- **Ways to instantiate a power copy? For instantiation you have to first select power copy which is previously created. This can be done through two ways. First way is through catalog and second way is from Insert > Instantiate from document.**

Creating Catalogs of Components

You will learn the main features of Catalog Workbench and tools to create and manage catalogs.

- Catalog Workbench Presentation
- Browsing Catalogs
- Creating Catalogs
- Creating Chapters
- Creating Families
- Creating Keywords
- Creating Components
- Creating Part Family Components
- Referencing Data from External Catalogs
- Checking the Catalog Preview
- Creating Catalogs in Batch Mode
- To Sum Up

Catalog Workbench Presentation

You will learn about the Catalog Workbench by



- **Accessing the Workbench**
- **Exploring the User Interface**
- **Exploring the Terminologies**
- **Understanding General Process**

What is a Catalog?

A Catalog is a file which provides fast access and pre-visualization of CATIA documents and features. It also classifies the documents or features on the basis of Chapters, Sub-Chapters and keywords.

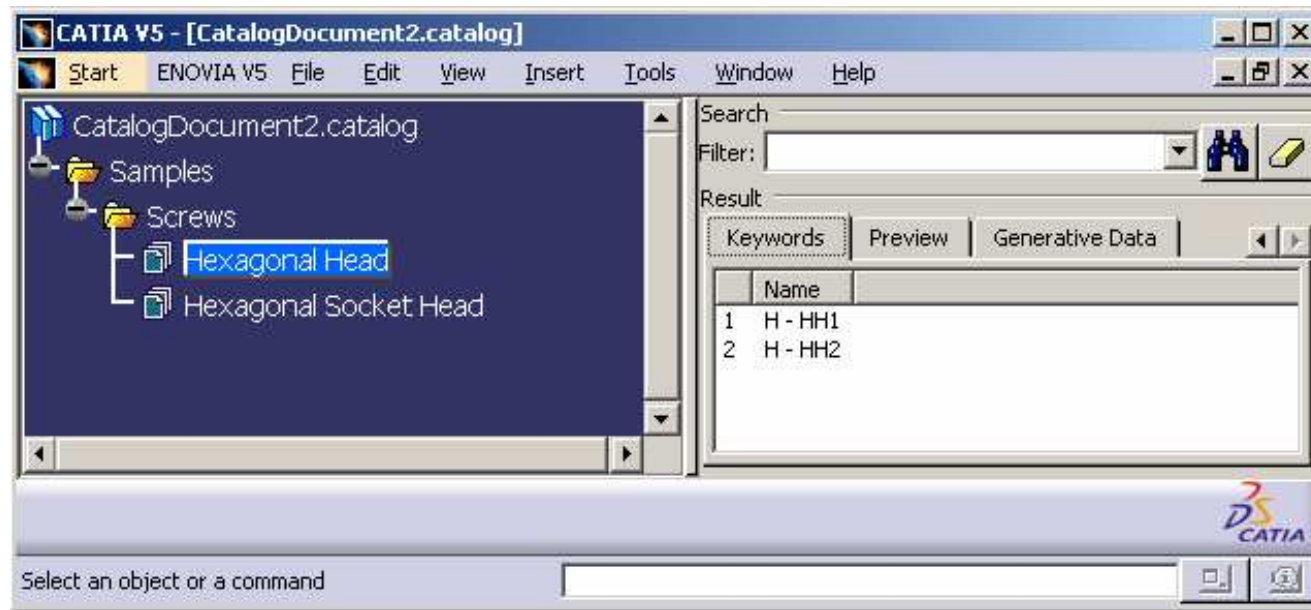

- A catalog references chapters and end chapters.
Example: Fasteners can reference Screws, Nuts, Bolts...
- Syntax used for creating catalogs and query comes from 'Knowlegeware'

Accessing the Workbench

To create and edit catalogs:

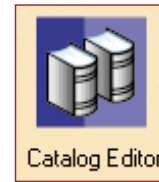
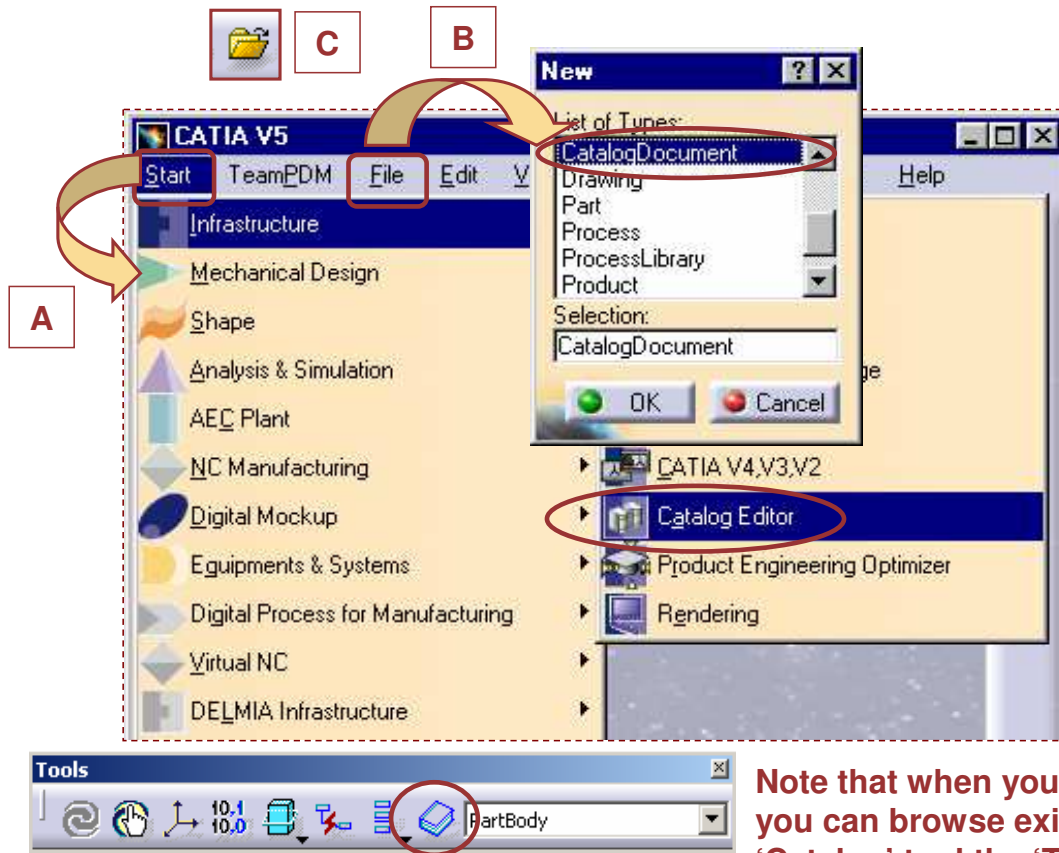

- Anywhere from the:
- A- Start menu
 - B- File / New menu
 - C- File / Open menu

Note that when you are in another workbench, you can browse existing catalogs using the 'Catalog' tool the 'Tools' toolbar.

User Interface: Toolbars

You will get acquainted with Toolbars

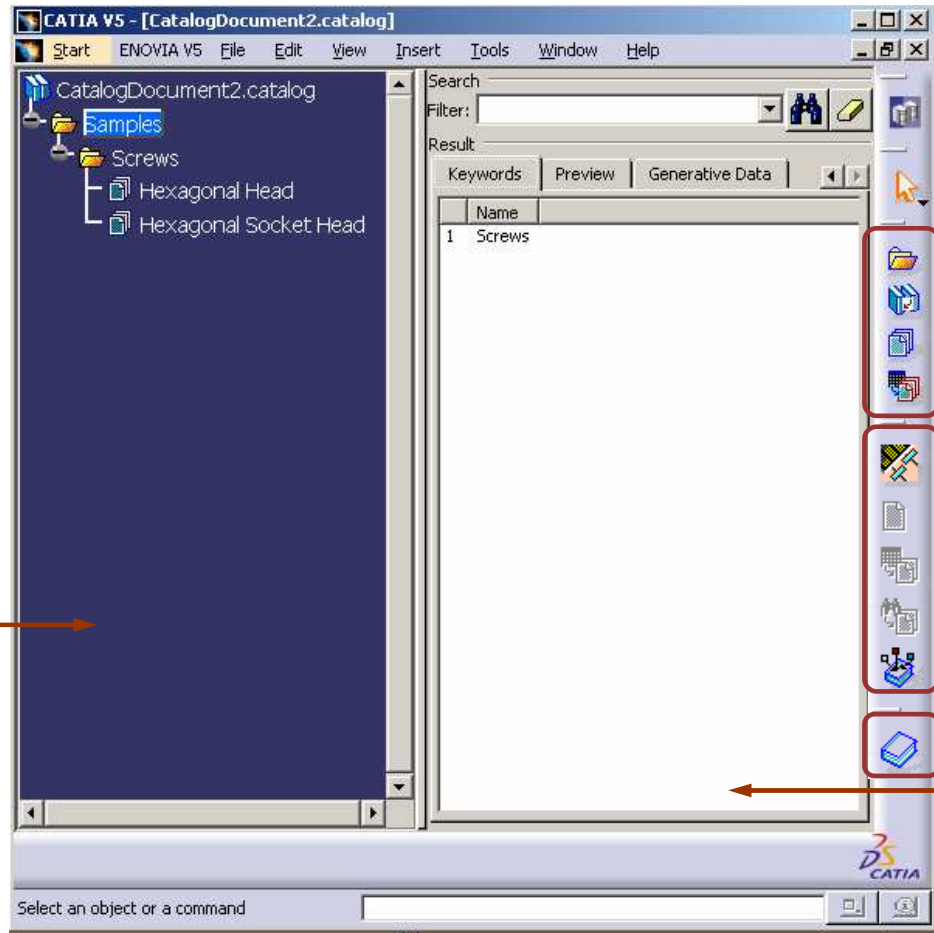

Tree Structure of the catalog, also called catalog navigator



Chapter Toolbar

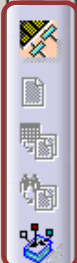

Data (description) Toolbar



Browsing Toolbar



Content description and preview of the catalog entities

Student Notes:

User Interface: Commands



Catalog Editor

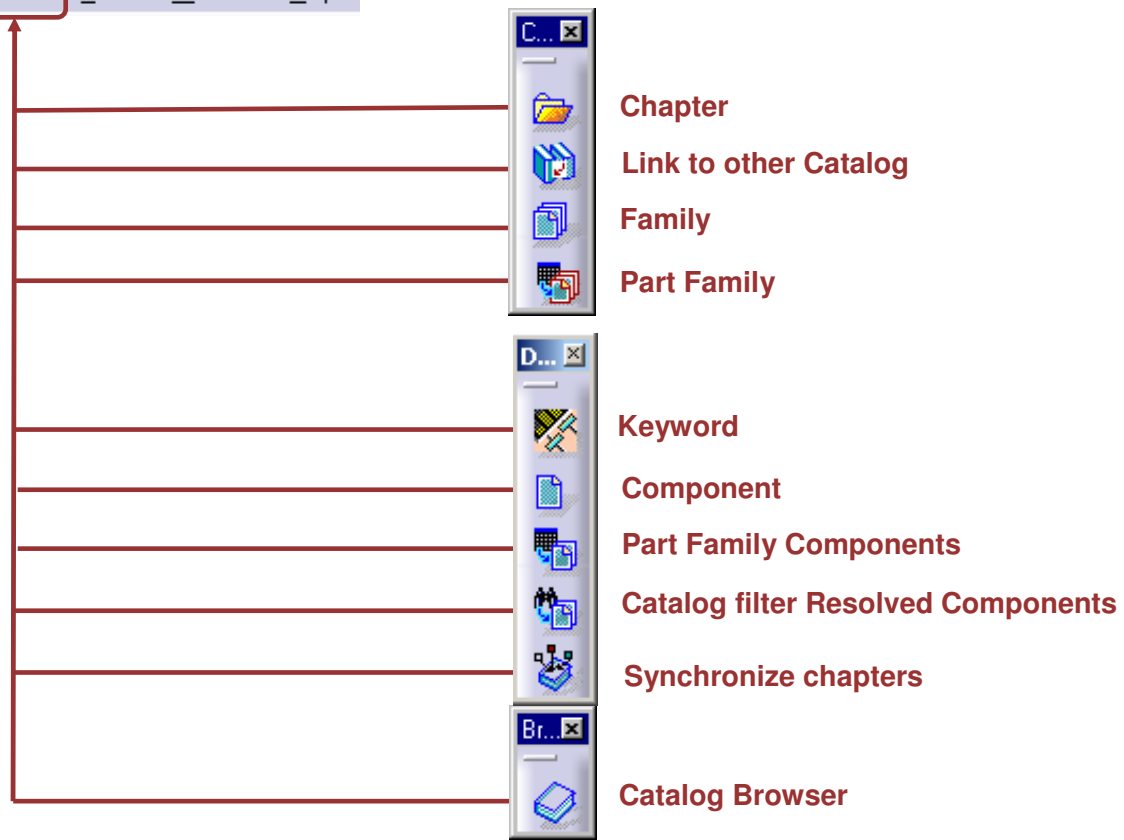

Terminologies

You will now get acquainted with Catalog terminology.

1 **Catalog:** A way of classifying many objects. A V5 catalog is in the form of a tree structure made up of chapters and families.



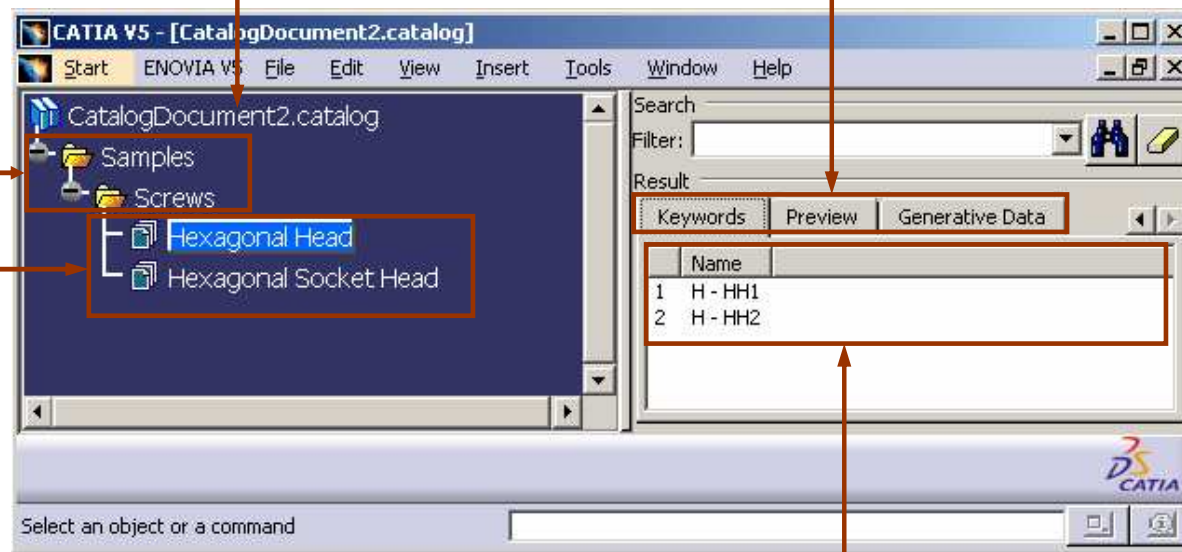

4 **Keyword:** The references are described using keywords such as name, type, diameter, length, etc. Keywords are then used to make a query in a catalog.

2 **Chapter:** A set of references. Made of chapters and families.

3 **Family:** A set of references. Made of entities which have the same classification.



Structure tree of the catalog indicates if the feature is :

- a Catalog 
- a Chapter 
- a family 
- if the feature comes from another catalog 

5 **Component:** Reference to an entity. It is displayed with its keyword values.
Entities: CATIA documents (CATPart or CATProduct...) that are referenced.

Student Notes:

General Process



Creating a new catalog



Browsing catalogs...



Insert objects in a document

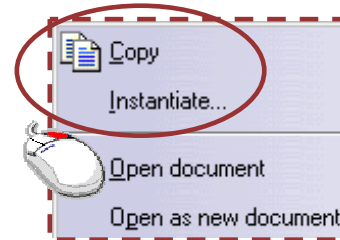

Student Notes:

Browsing Catalogs

You will learn how to search and use objects from catalogs

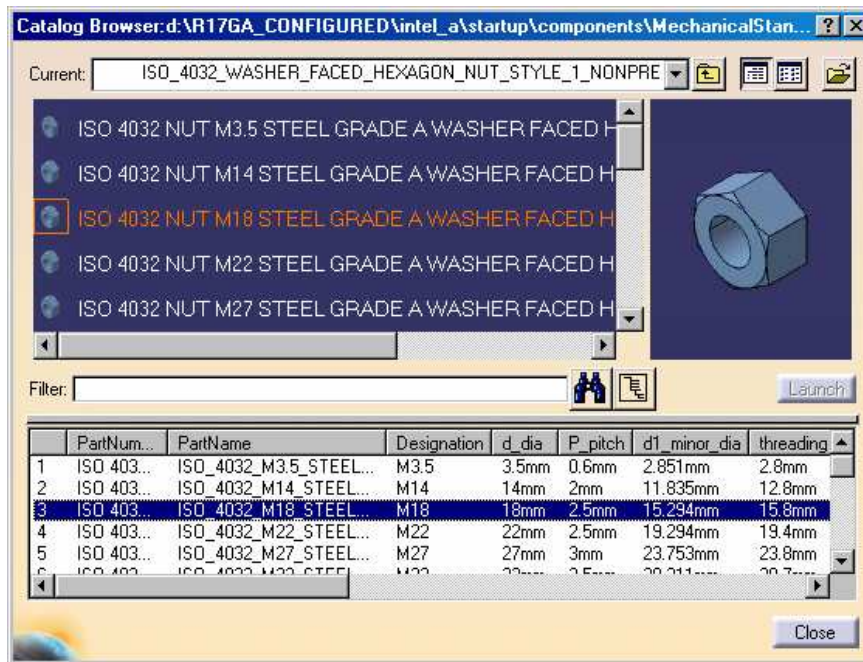

Catalog browser dialog box

What is Browsing a Catalog

The Catalog Browser is a tool available in several workbenches which allows you to view catalogs. Using the catalog browser, you can have previews and know the descriptions of elements referenced in them. You can also sort them out with queries and insert them in your current document.

Current chapter displayed

Elements referenced in the current chapter

Query field to narrow down your search

Descriptions table

Access to father chapter

Display Modes

Selects another catalog

Selected element preview



Query Launcher

Launch the supporting document in an external process

Catalog browser dialog box

Browsing Catalogs

In a catalog, you can have chapters, families, documents and features that are referenced. Here is a way to navigate through them.
 Save and close the GeneralEnd.catalog.

- 1 Click the Catalog tool. It opens the catalog browser

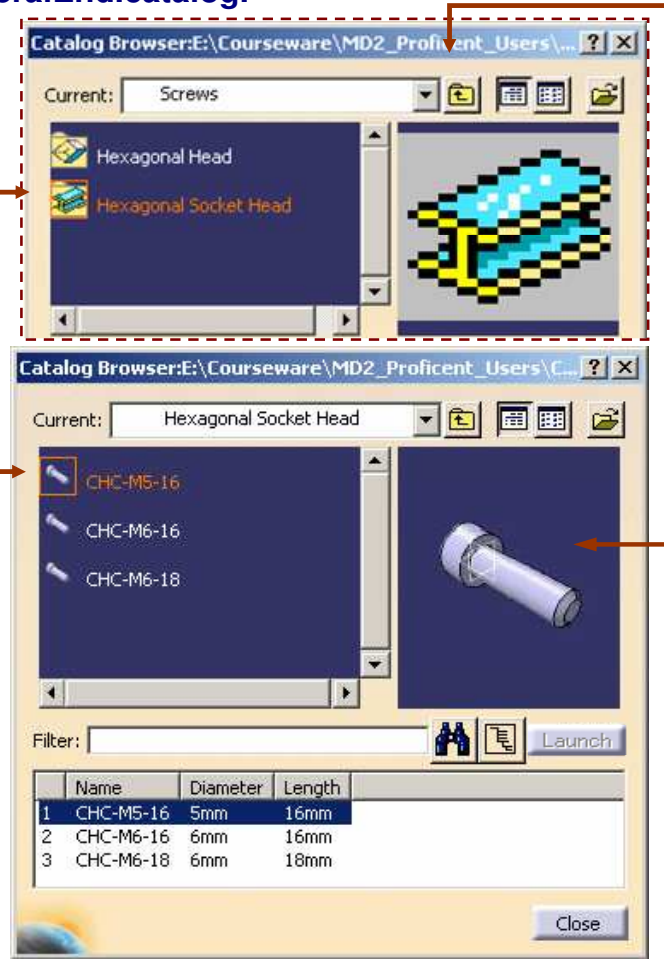
- 3 Double click a chapter icon to open it
 2 x
- 4 Click on an element icon to get its preview



2 Click the Open icon to select a catalog.
 Click the 'Up one level' icon to go back to the parent chapter

You get the preview and the description of the selected object

Inserting a Component from a Catalog

Here is one of the methods to insert a component from a Catalog.

- 1 Select component in which part from catalog is to be added.
- 2 Click the Catalog icon. It opens the catalog browser
- 3 Open chapters until you get the last chapter in which the element you want is referenced.

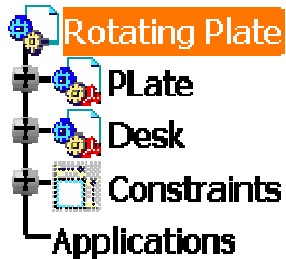

- 4 Use contextual menu and copy the element

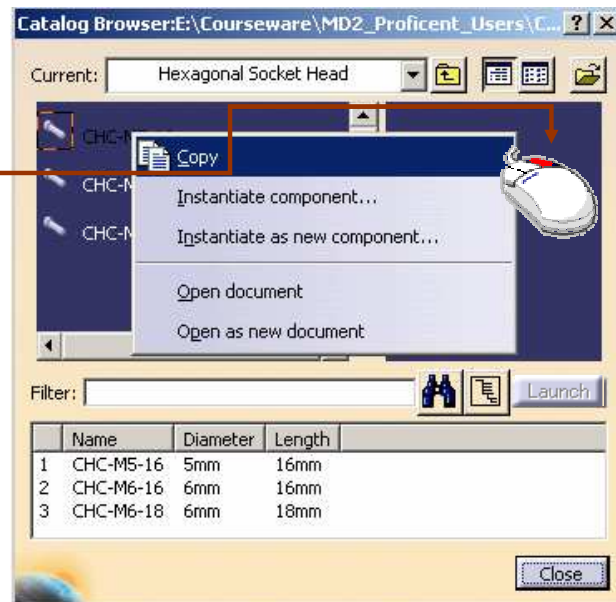

- 5 Paste the object into your document

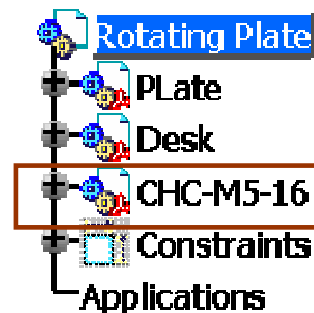

To insert an object you can also drag and drop it into your destination document

Sorting Out Components with Queries (1/4)

While browsing a catalog family, you can apply a filter to sort components respecting your query.

- 1 Have a look at the keywords and note the keywords.

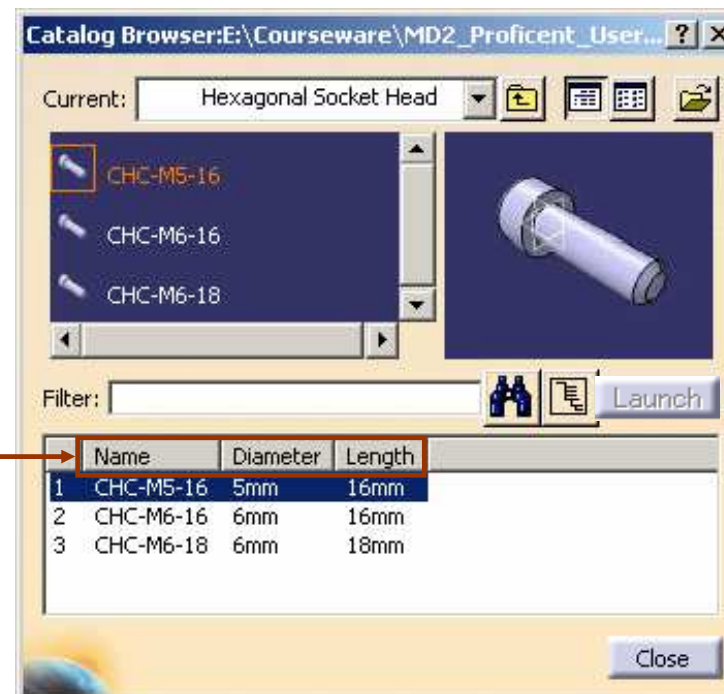

Sorting Out Components with Queries (2/4)

Specify your query for the filter

2 Click on this tool

The 'Filter' panel will open.

Name	Diameter	Length
1 CHC-M5-16	5mm	16mm
2 CHC-M6-16	6mm	16mm
3 CHC-M6-18	6mm	18mm

Name	Diameter	Length
1 CHC-M6-16	6mm	16mm
2 CHC-M6-18	6mm	18mm

Property	Operator	Value
Diameter	==	6mm
Length		0mm

Sorting Out Components with Queries (3/4)

The way to build a specification will be different depending upon whether the value of the concerned keyword is numeric or alphanumeric.

3 Key your specification in the Filter field

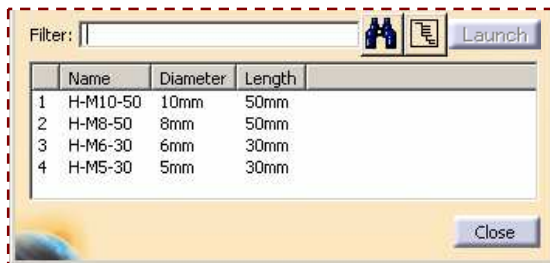

For numeric values (Length, Weight...) use expressions like :

x. for "value of..."
 Keyword (with exact spelling)
 Operator (<=, >=, or == for comparison)
 Reference value (do not forget the unit!)

x.Length >= 50mm



4 Click on  to apply the filter

5 Only components respecting the specification are displayed

For alphanumeric values (string,...) use expressions like :

Same kind of expression as for the numeric values (but only == does work as Operator and you need to delimit Reference value with ")

x.Name == "H-M6-30"
 or
 x.Name.Search("H-M6-30")>=0

To select all the values of the keyword containing the chain of characters H-M6-30

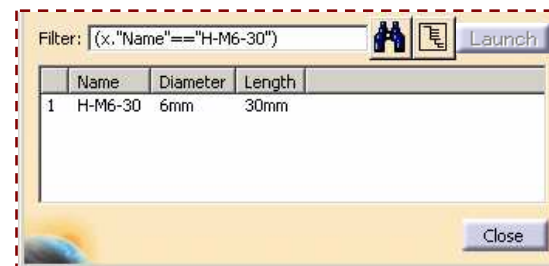

Sorting Out Components with Queries (4/4)

You can also combine effects of two specifications to build a query

- 6 Apply the first filter condition then you can use the 'add' operator for next condition.

Filter: 



	Name	Diameter	Length
1	CHC-M5-16	5mm	16mm
2	CHC-M6-16	6mm	16mm
3	CHC-M6-18	6mm	18mm
4	CHC-M10-40	10mm	40mm
5	CHC_M10_60	10mm	60mm

Filter: 

	Name	Diameter	Length
1	CHC-M5-16	5mm	16mm
2	CHC-M6-16	6mm	16mm



Filter: 

	Name	Diameter	Length
1	CHC-M6-16	6mm	16mm
2	CHC-M6-18	6mm	18mm

Filter:  

	Name	Diameter	Length
1	CHC-M6-16	6mm	16mm

Intersection of results of both specifications

Filter:  

	Name	Diameter	Length
1	CHC-M5-16	5mm	16mm
2	CHC-M6-16	6mm	16mm
3	CHC-M6-18	6mm	18mm

Union of results of both specifications

Creating Catalogs

You will learn how to create catalogs file from scratch

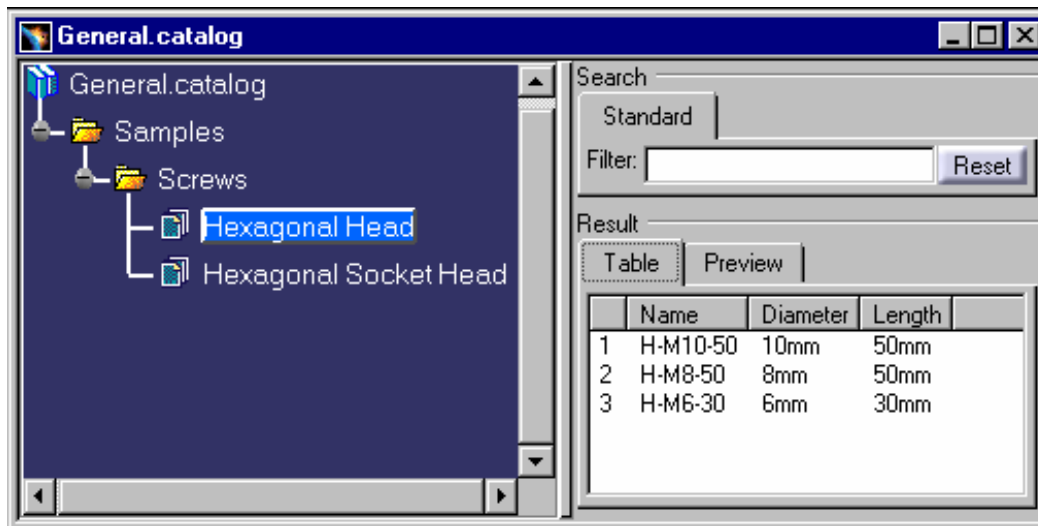

A catalog

Creating Catalogs

There are several options to create CATIA V5 Catalogs...

...You can create an empty catalog from scratch...



...You can save a CATPart containing Power copies as a catalog ...

...Or you can save CATDrawing files containing details sheets and dittos as a catalog

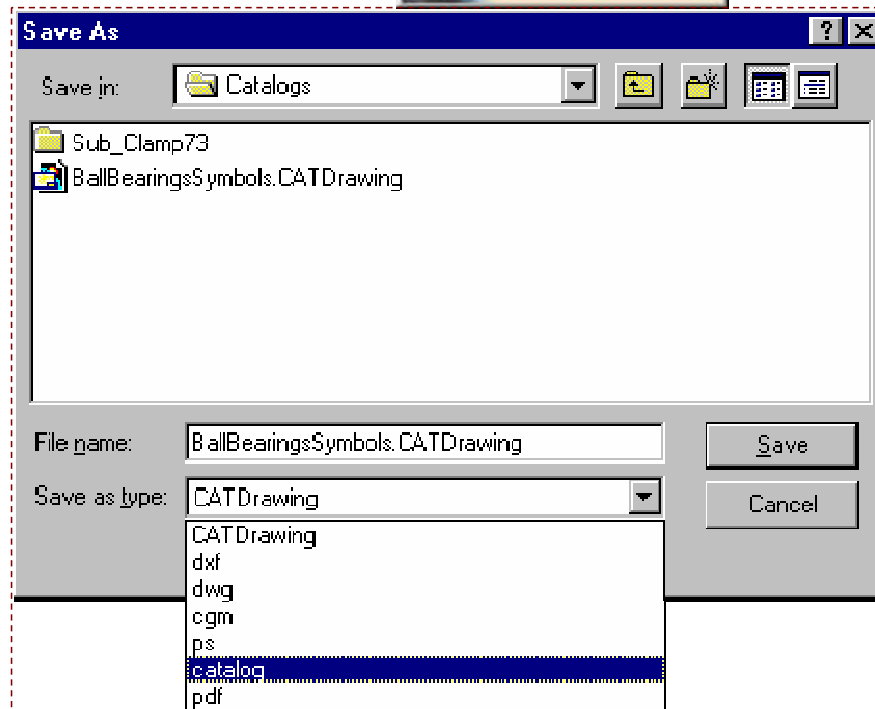

Creating a New Catalog (1/2)

Starting the 'Catalog Editor' workbench will create an empty catalog with a first chapter.

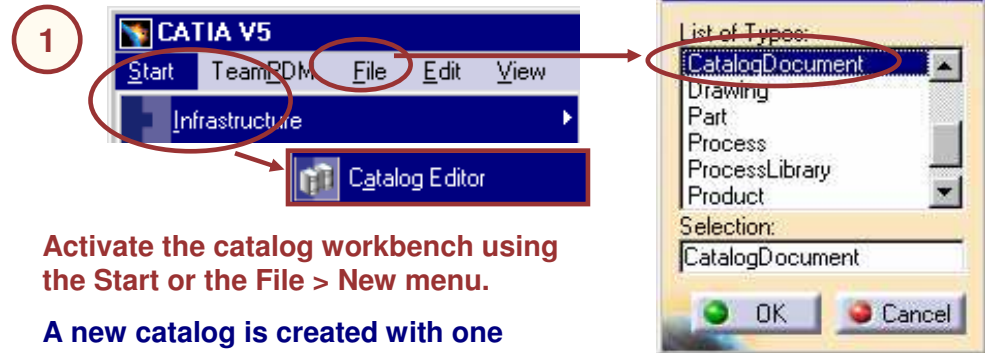

Activate the catalog workbench using the Start or the File > New menu.

A new catalog is created with one chapter

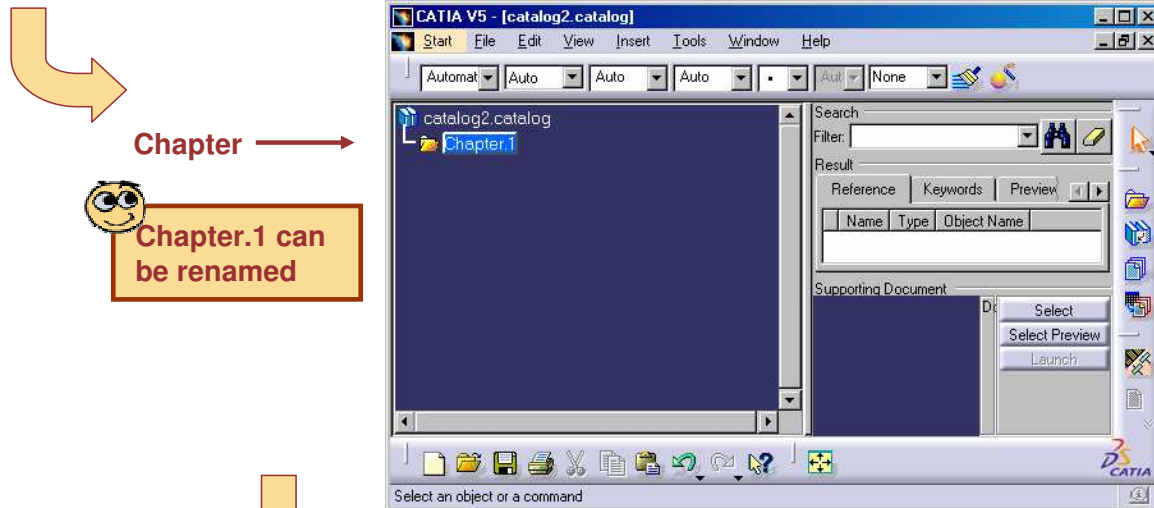

Chapter.1 can be renamed

2 Save the catalog to rename it (File > Save As...)

Student Notes:

Creating a New Catalog (2/2)

Creating a catalog interactively involves the following process

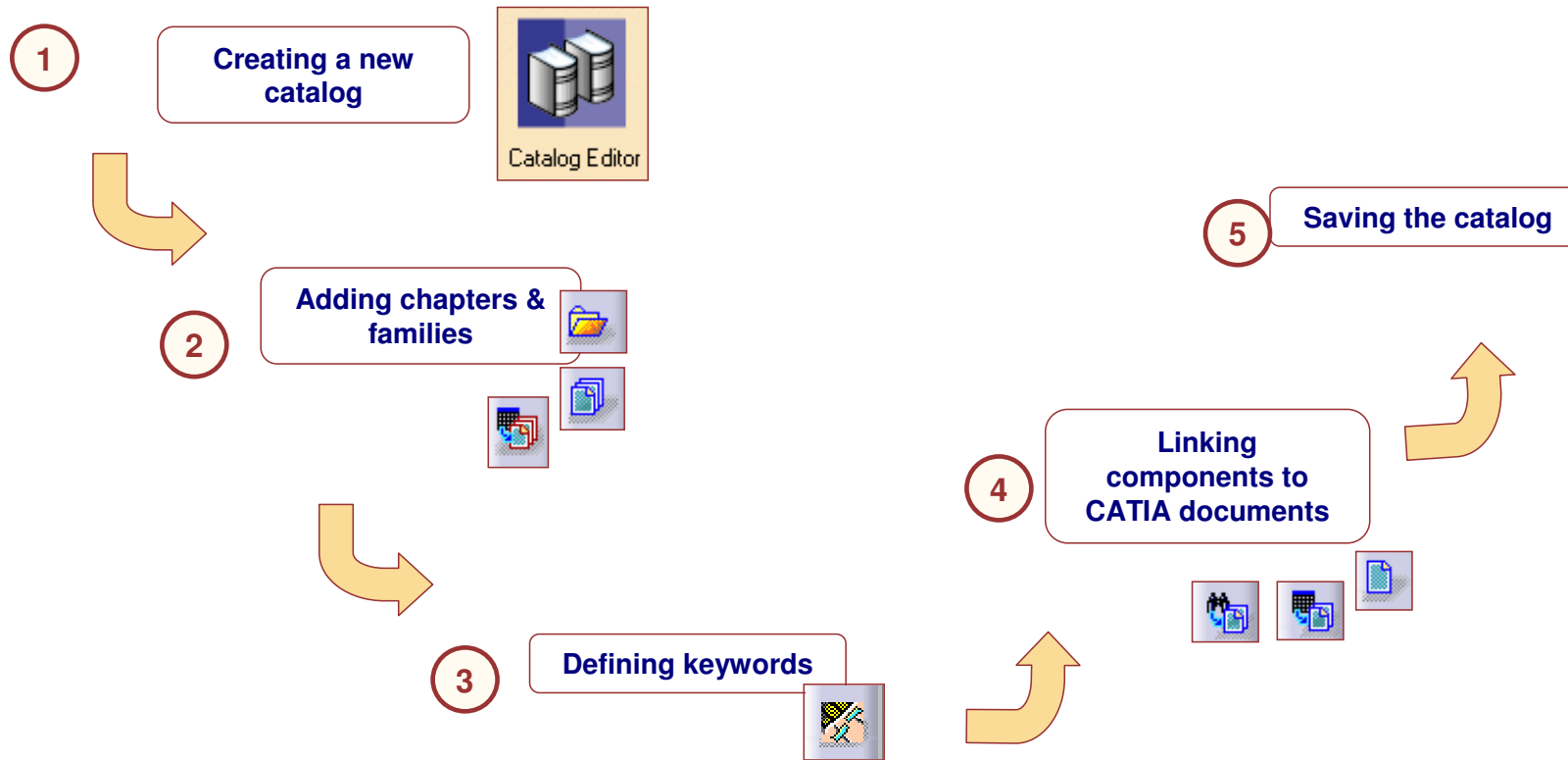

Creating a Catalog from a CATDrawing file (1/2)

You can save CATdrawing files containing details sheets and dittos as catalogs

1 Select "Save as..." command from File menu

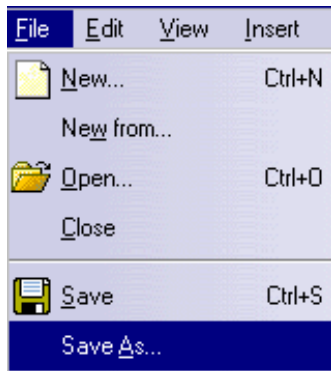

2 Select catalog for the type of the file

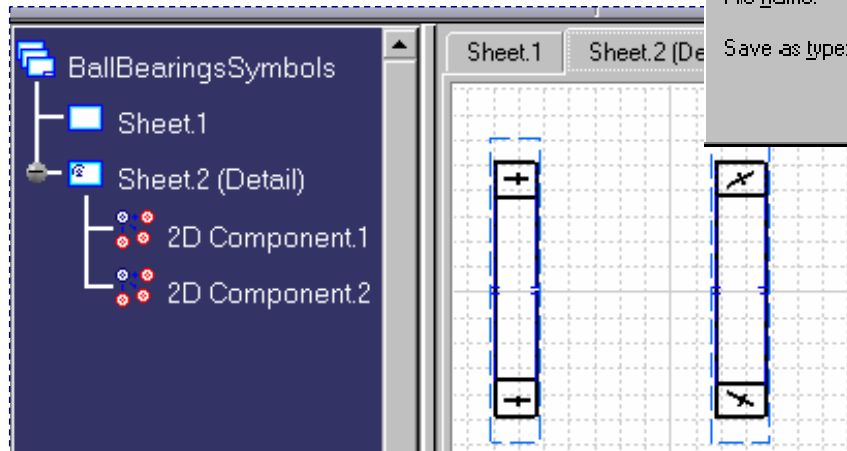
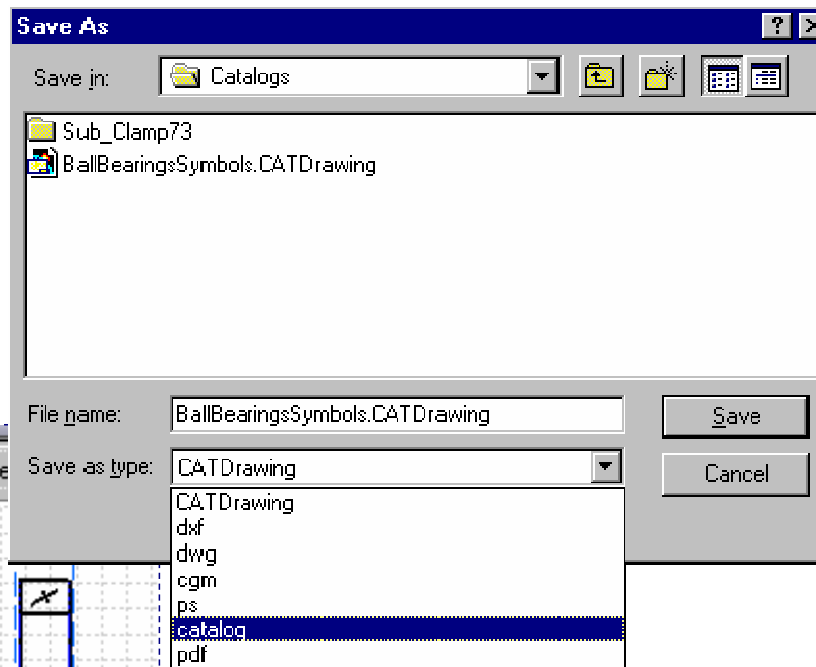

Only 2dComponents that are in detail sheets will be referenced in the created catalog.

Creating a Catalog from a CATDrawing file (2/2)

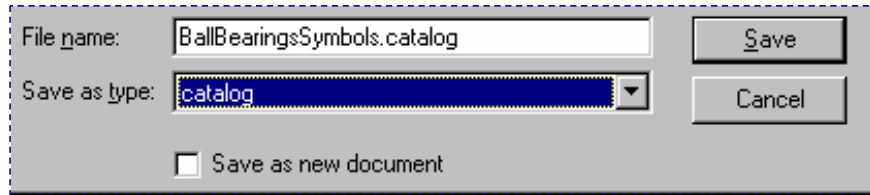

3 Save the catalog file.

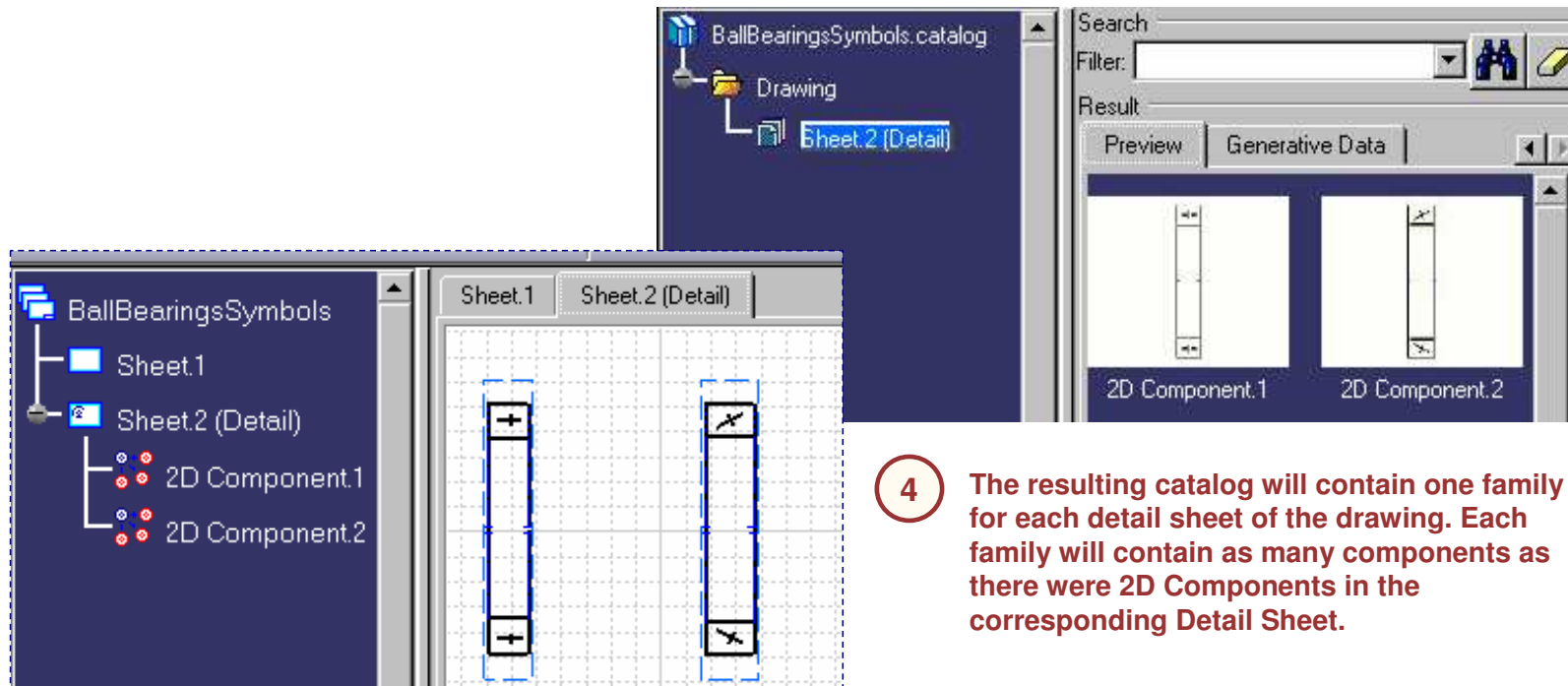

4 The resulting catalog will contain one family for each detail sheet of the drawing. Each family will contain as many components as there were 2D Components in the corresponding Detail Sheet.

Creating Chapters

You will learn how to create chapters.

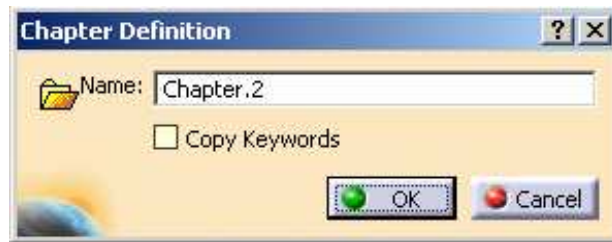

What is a Chapter?

A Chapter is a set of references. It references other Chapters or Families.

Chapter referencing another chapter

Chapter referencing two Families

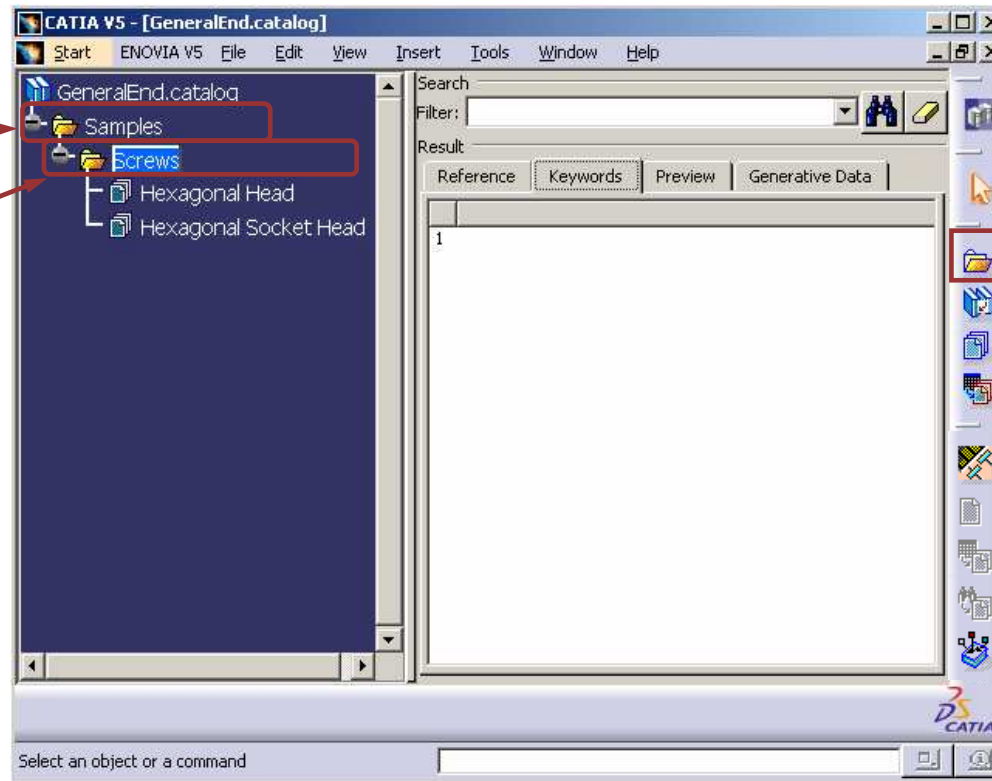

Chapter Definition Box



Adding a Chapter to a Catalog

A chapter is a set of references. It can refer to other chapters or to families.

- 1 Open the catalog you want to modify (File > Open)
- 2 Edit the Chapter under which you want to create a new chapter
- 3 Select the "Chapter" icon
- 4 Type the name of the Chapter
- 5 Click OK to confirm the chapter creation
The chapter is added in the tree

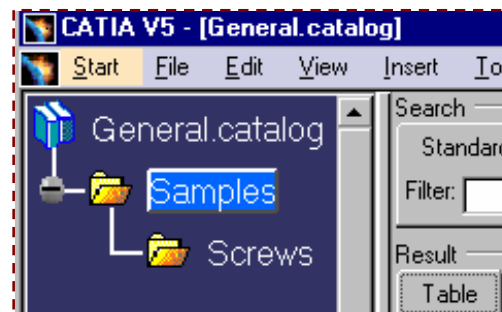
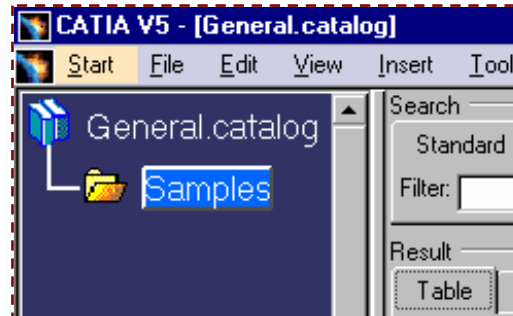

- A Family will reference CATIA documents or features whereas a Chapter will reference other Chapters or Families
- You cannot create any Chapter under a Family

Creating Families

You will learn how to create families that can contain reference to CATIA documents and Features.

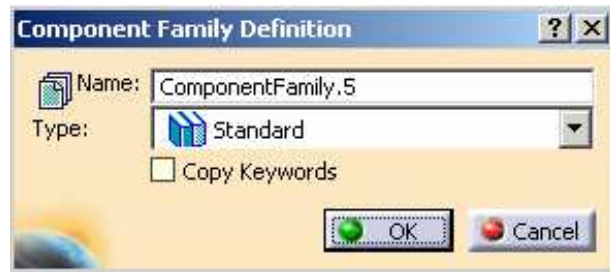

What is a Family?

A family is a set of references. It references components that can be CATIA documents (CATProduct or CATPart) or CATIA Features (Details or Power copies).

Families

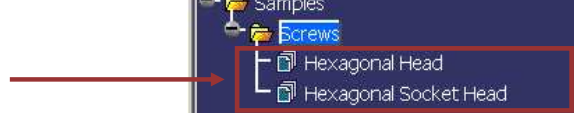

Family Definition Box

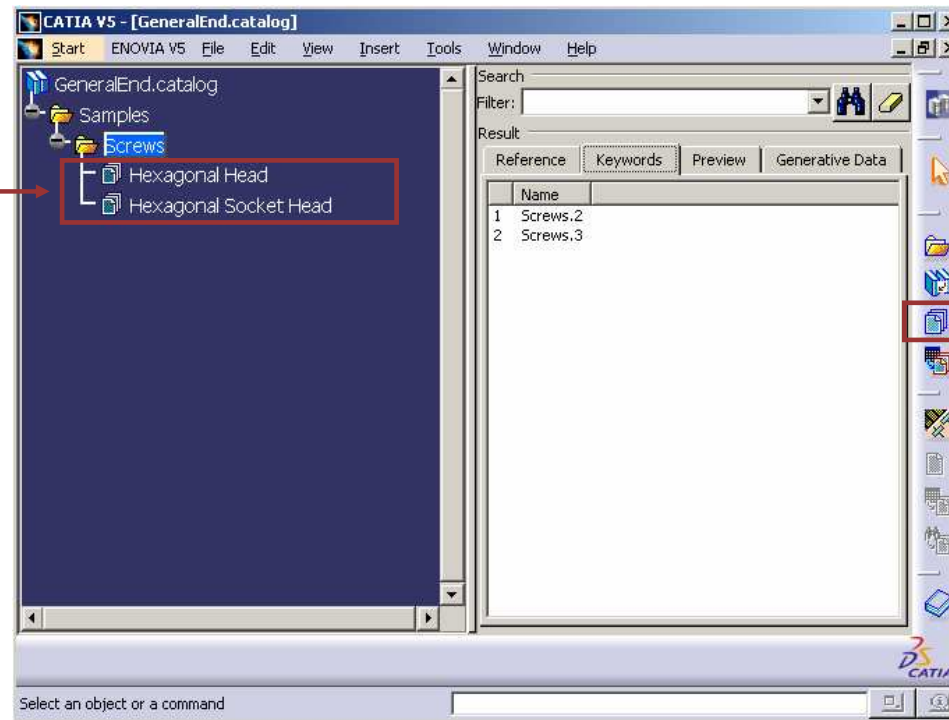

Adding a Family

A family is a set of references. It refers to CATIA documents (CATPart or CATProduct) or features (Drawing Details or Power Copy)

1 Open the catalog you want to modify (File > Open)

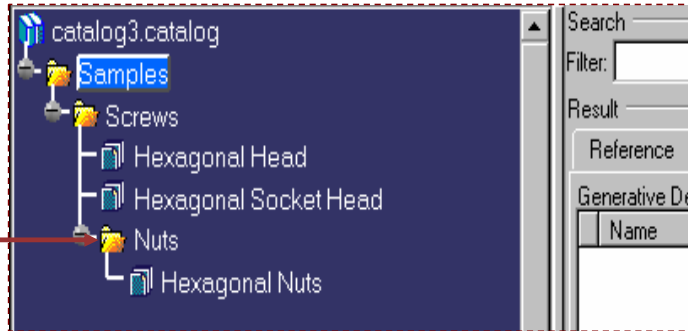

2 Edit the Chapter under which you want to add the family.

3 Select 'Family' icon 



4 Type the name of the family to create

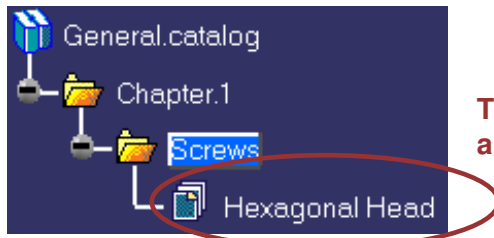

The new family appears in the tree

5 Click OK to confirm the creation



- A Family will reference CATIA documents or features whereas a Chapter will reference other Chapters or families
- You can not create any Chapter under a Family

Creating Keywords

You will learn how to create keywords in order to describe contents of chapters and families

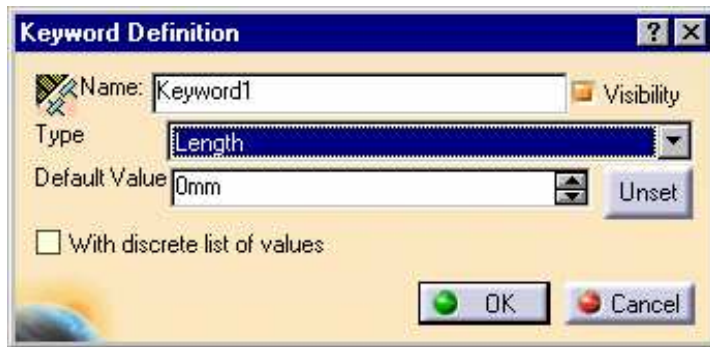

What is a Keyword?

Keywords allow you to characterize references in a chapter or family. Values of keywords will help you sort them out when searching for an object (query).

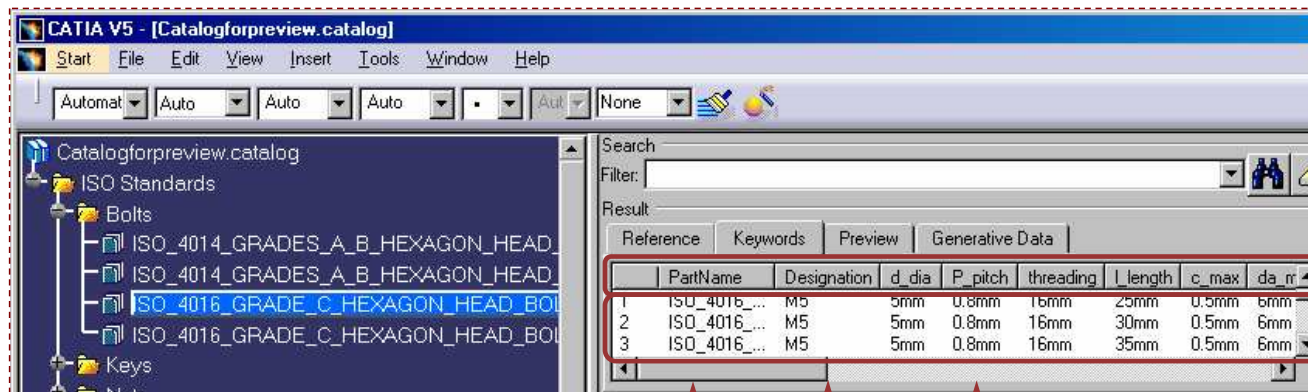

Keywords' name

Keywords' value

Creating a Keyword in a Catalog

The keywords allow you to characterize the references in the chapter or family. Values of keywords will help you to sort out references with queries.

- 1 Activate the Family or Chapter in which you want to add a keyword.

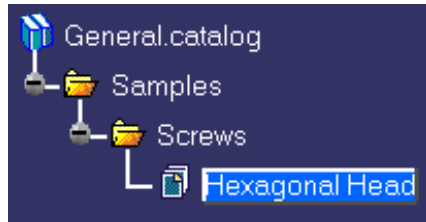

- 2 Select the Keyword icon



This option will determine if values of this keyword are visible through the browser or not

- 3 Type the name of the keyword

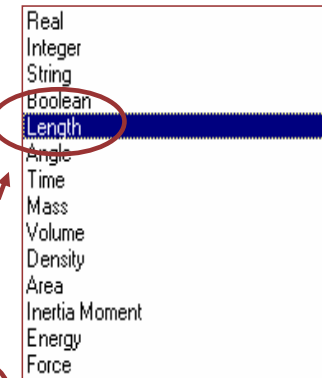
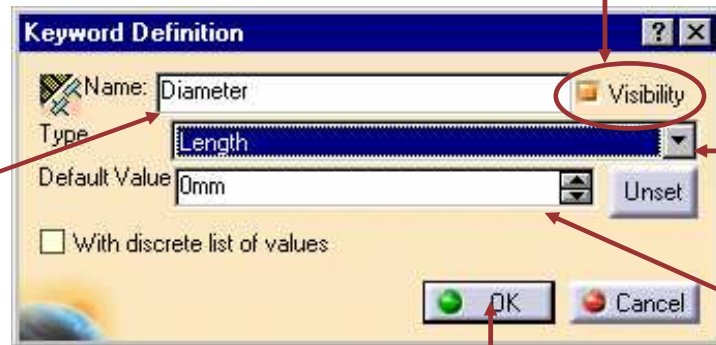

- 4 From the list, select the desired type of the keyword.

- 5 Set the default value of the Keyword.

- 6 Click OK



The new keyword appears in the Table tab in the result window.

To modify a keyword you can use the contextual menu on a chapter (objectname... > Keywords...) or on a component (Keywords...)

Creating Components

You will learn how to create references to CATIA documents or Features.

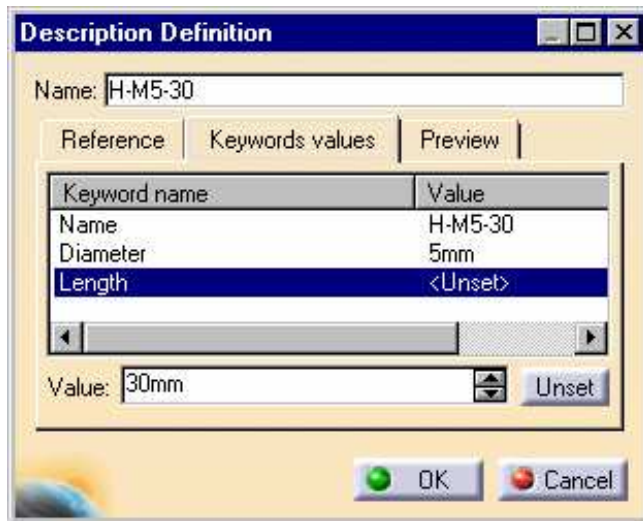

What is a Component?

A Component is a reference to an external document or feature.

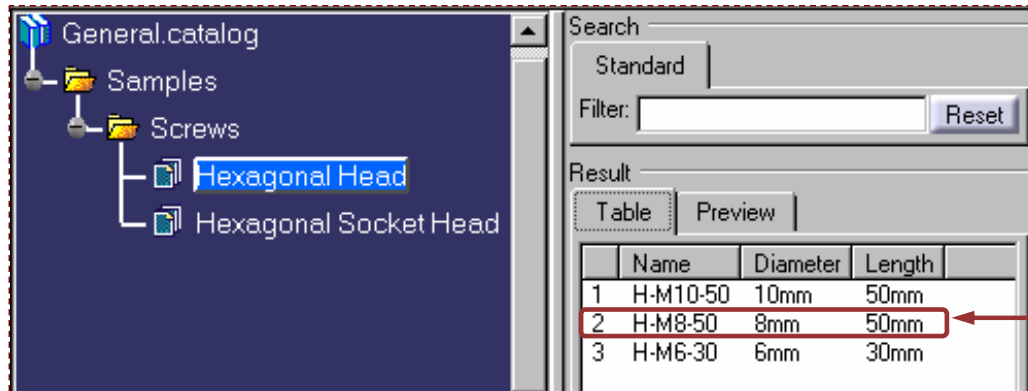

A component

Path of the CATIA document

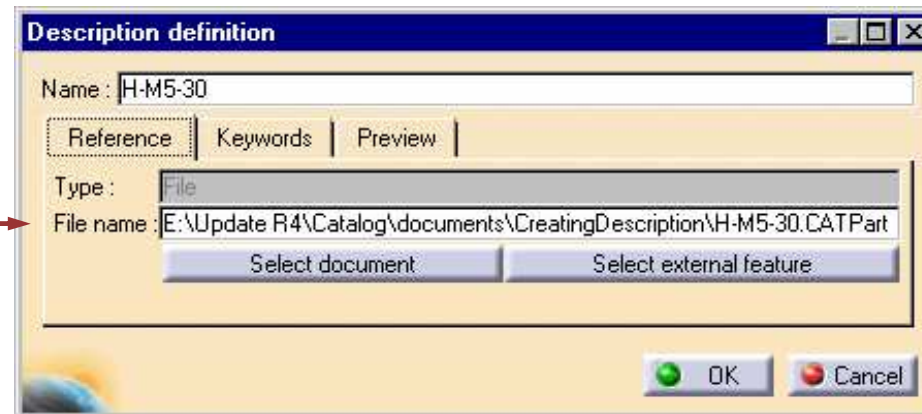

Description definition box

Adding a Component

A Component is a reference to an external file or feature described with keyword settings.

1 Activate the family in which you want to add a component

2 Select the Component tool.

3 Click on Select document to link a CATIA document

4 Select the desired CATIA file
 - The path of the selected document will be displayed in the File Name field

5 In the Keyword tab, set values for keywords by selecting the keyword and typing the value

You can preview the associated documents (Preview tab)

6 Click OK

Description is created

You can edit the default name

The Select external feature button allows you to select PowerCopies or Details.

Creating Part Family Components

You will learn how to create complete sets of components from single CATPart file.



What are Part Family Components? (1/2)

Part Family Components are sets of components generated from a single Part which has several configurations referenced in a Design Table. For each configuration described in the Design Table, a part family component will be created.

NutDesignTable.xls

	A	B	C	D	E
1	A (mm)	HALFh (mm)	DIAMETER (mm)	PAS (mm)	PartNumber
2	3.2	0.65	1.6	0.35	H_M1_6_8
3	4	0.8	2	0.4	H_M2_8
4	5	1	2.5	0.45	H_M2_5_8
5	5.5	1.2	3	0.5	H_M3_8
6	7	1.6	4	0.7	H_M4_8

All possible configurations of this part are stored in the file leading the Design Table (Exel file or tabulated text file)

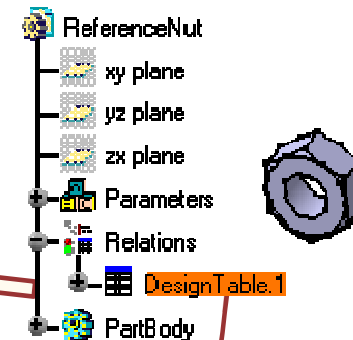

Keywords will be created directly from names of the parameters (columns) in the Design Table

This icon allows you to generate a complete family from a single CATPart

General.catalog

General.catalog

- Samples
- Screws
- Nuts
 - Hexagonal Nuts

Search

Filter: Reset

Result

Table Preview

	A	HALFh	DIAMETER	PAS	PartNumbe
1	3.2mm	0.65mm	1.6mm	0.35mm	H_M1_6_8
2	4mm	0.8mm	2mm	0.4mm	H_M2_8
3	5mm	1mm	2.5mm	0.45mm	H_M2_5_8
4	5.5mm	1.2mm	3mm	0.5mm	H_M3_8
5	7mm	1.6mm	4mm	0.7mm	H_M4_8
6	8mm	2.35mm	5mm	0.8mm	H_M5_8
7	10mm	2.6mm	6mm	1mm	H_M6_8

In the Design Table where all the configurations are defined, a column describing the PartNumber is required.

Student Notes:

What are Part Family Components? (2/2)

You can either edit a Chapter and create a Part Family in it that references all components described by the Design Table

Reference	Keywords			Preview	Generative Data
	d	e	D		PartNumber
1	6mm	2mm	12mm		ThickWasher_Z6
2	8mm	3mm	16mm		ThickWasher_Z8
3	10mm	3mm	20mm		ThickWasher_Z10
4	12mm	3.5mm	24mm		ThickWasher_Z12
5	14mm	4mm	30mm		ThickWasher_Z14
6	16mm	4.5mm	32mm		ThickWasher_Z16
7	20mm	5mm	40mm		ThickWasher_Z20
8	24mm	6mm	50mm		ThickWasher_Z24
9	30mm	7mm	60mm		ThickWasher_Z30

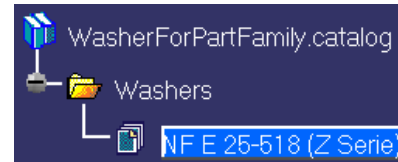
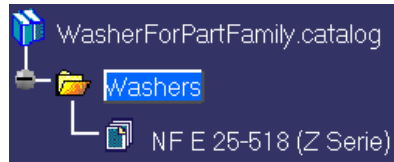
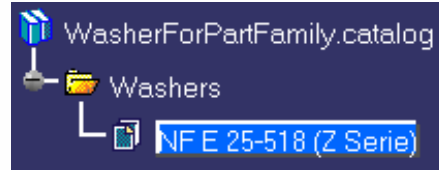

Or you can edit an already existing family and create all references of components described by the Design Table in it.

Reference	Keywords			Preview	Generative Data
	d	e	D		PartNumber
1	6mm	3mm	16mm		ThickWasher_L6
2	8mm	4mm	22mm		ThickWasher_L8
3	10mm	4mm	27mm		ThickWasher_L10
4	12mm	5mm	32mm		ThickWasher_L12
5	14mm	5mm	40mm		ThickWasher_L14
6	16mm	6mm	45mm		ThickWasher_L16
7	20mm	6mm	55mm		ThickWasher_L20
8	24mm	7mm	65mm		ThickWasher_L24

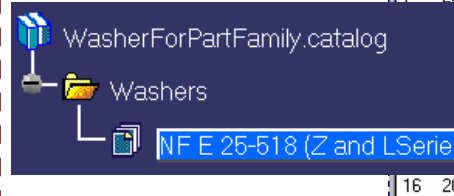
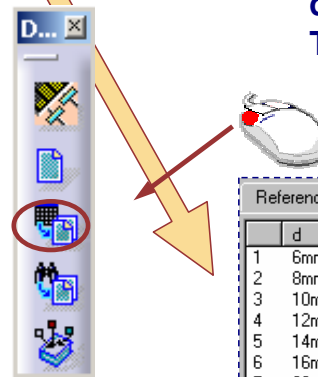
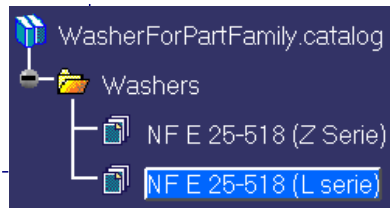
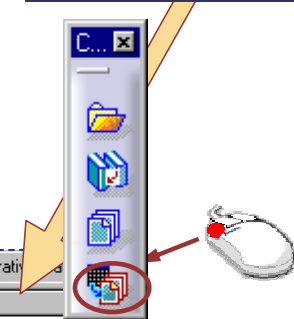

Reference	Keywords			Preview	Generative Data
	d	e	D		PartNumber
1	6mm	2mm	12mm		ThickWasher_Z6
2	8mm	3mm	16mm		ThickWasher_Z8
3	10mm	3mm	20mm		ThickWasher_Z10
4	12mm	3.5mm	24mm		ThickWasher_Z12
5	14mm	4mm	30mm		ThickWasher_Z14
6	16mm	4.5mm	32mm		ThickWasher_Z16
7	20mm	5mm	40mm		ThickWasher_Z20
8	24mm	6mm	50mm		ThickWasher_Z24
9	30mm	7mm	60mm		ThickWasher_Z30
10	6mm	3mm	16mm		ThickWasher_L6
11	8mm	4mm	22mm		ThickWasher_L8
12	10mm	4mm	27mm		ThickWasher_L10
13	12mm	5mm	32mm		ThickWasher_L12
14	14mm	5mm	40mm		ThickWasher_L14
15	16mm	6mm	45mm		ThickWasher_L16
16	20mm	6mm	55mm		ThickWasher_L20

Adding a Part Family (1/2)

A Part Family will display several components but all of them will be generated from configurations of a single CATpart file. Those configurations are defined in a Design Table.

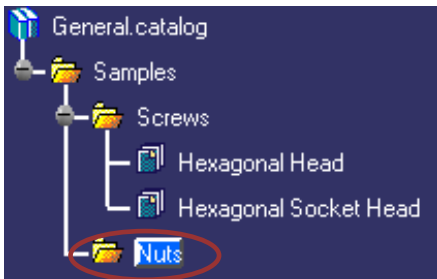

1

Activate the chapter under which you want to add the part family.

2



Select the "Add Part Family" tool

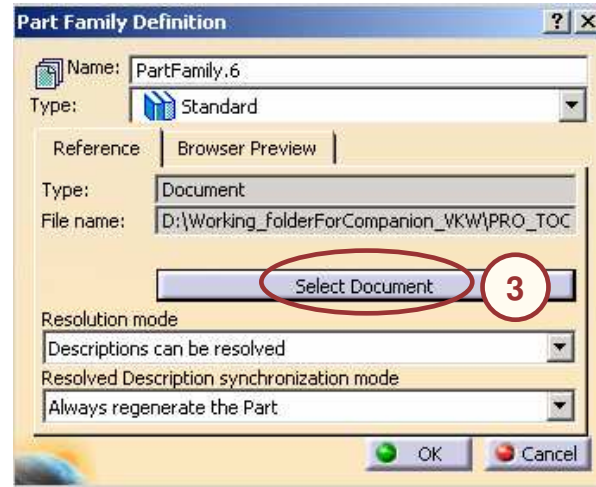

3

Click on "Select document" to link a CATIA document



In the Design Table where all the configurations are defined, a column describing the PartNumber is required.

	A (mm)	B (mm)	DIAMETER (mm)	L (mm)	E
					PartNumber
2	3.2	0.65		1.6	0.35 H_M1_6_8
3	4	0.8		2	0.4 H_M2_8
4	5	1		2.5	0.45 H_M2_5_8
5	5.5	1.2		3	0.5 H_M3_8
6	7	1.6		4	0.7 H_M4_8

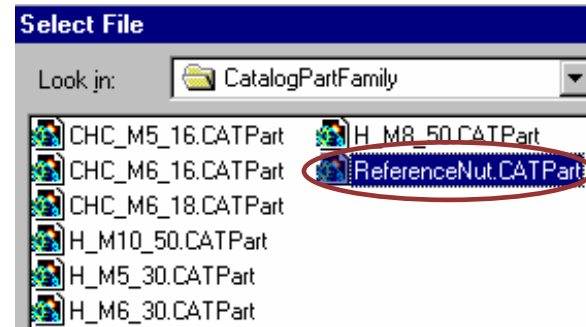

4

Select the desired CATIA file

Adding a Part Family (2/2)

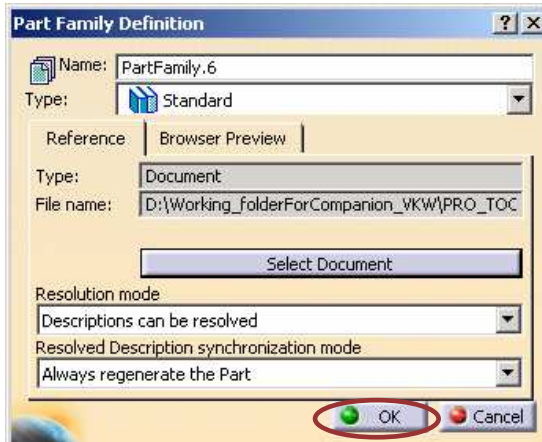

5 Click OK

Each component has a preview available

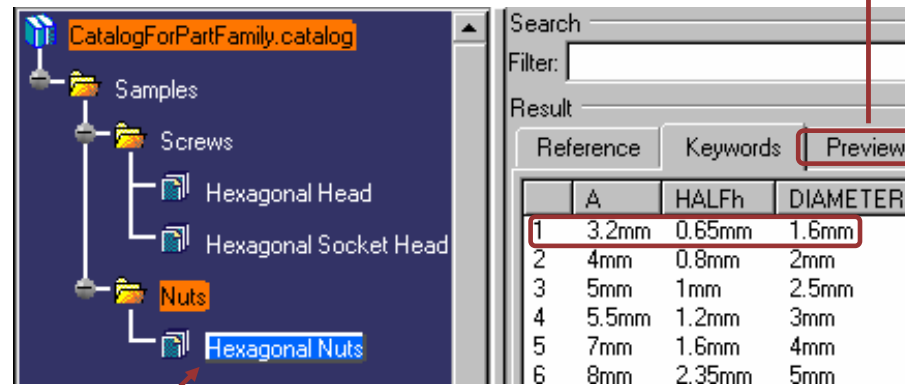

6 The Part family is created and contains as many components as the number of rows in the Design Table of the Part.



if not resolved, the description of each component will refer to the same .CATPart File

Adding a Part Family Component (1/2)

A Part Family component is a set of components. All of them will be generated from configurations of a single CATpart file. Those configurations are defined in a Design Table .

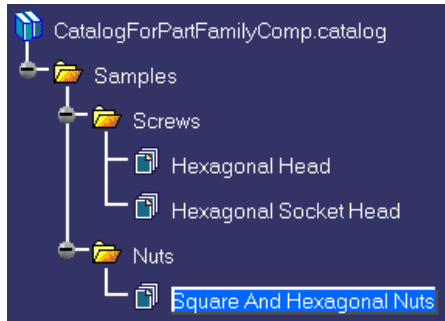

1 Activate the family under which you want to add the part family component



2 Select the "add Part Family Component" tool

3 Click on "Select document" to link a CATIA document

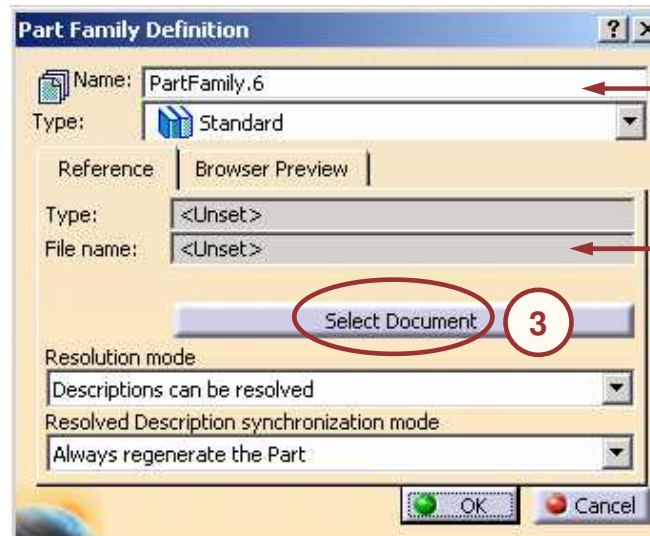

You can edit the default name

The path of the selected document will be displayed here.

In the Design Table where all the configurations are defined, a column describing the PartNumber is required.

					E	
					PartNumber	
1	A				0.35	H_M1_6_8
2					0.4	H_M2_8
3	4	0.8		2	0.45	H_M2_5_8
4	5	1		2.5	0.5	H_M3_8
5	5.5	1.2		3	0.7	H_M4_8
6	7	1.6		4		

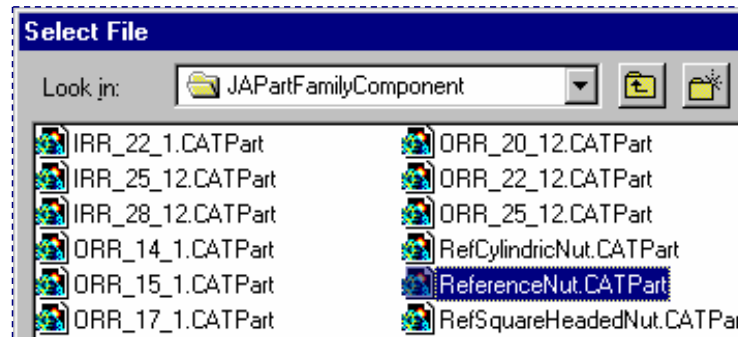

4 Select the desired CATIA file

Adding Part Family Components(2/2)

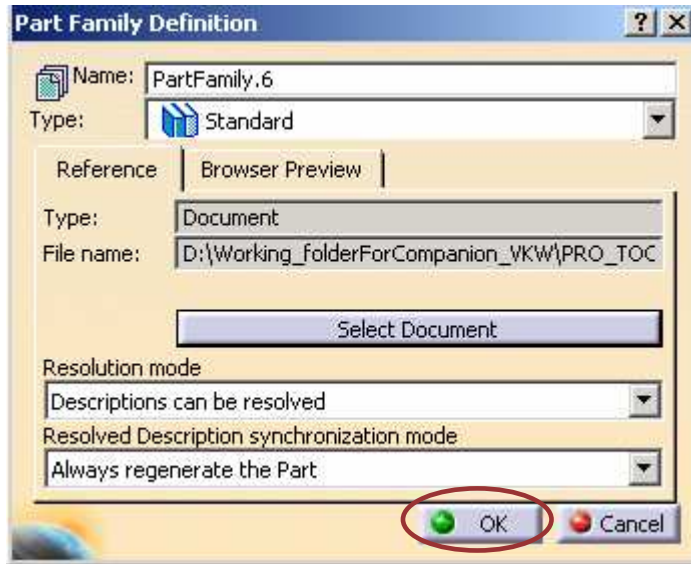

Each component has a preview available

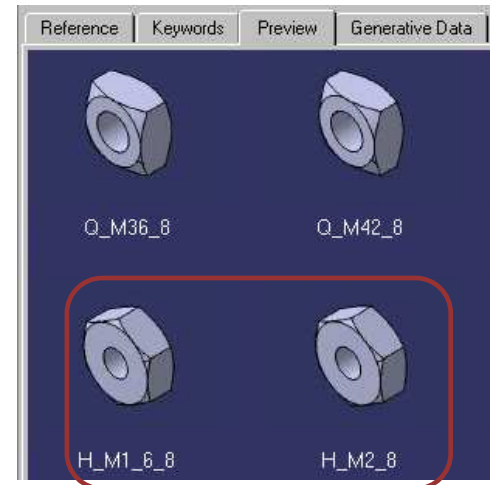

5 Click OK

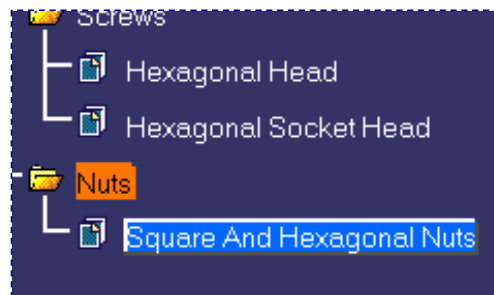

	A	HALFh	DIAMETER	PAS	PartNumber
15	46mm	12.8mm	30mm	3.5mm	Q_M30_8
16	55mm	15.5mm	36mm	4mm	Q_M36_8
17	65mm	17mm	42mm	4.5mm	Q_M42_8
18	75mm	19mm	48mm	5mm	Q_M48_8
19	3.2mm	0.65mm	1.6mm	0.35mm	H_M1_6_8
20	4mm	0.8mm	2mm	0.4mm	H_M2_8
21	5mm	1mm	2.5mm	0.45mm	H_M2_5_8
22	5.5mm	1.2mm	3mm	0.5mm	H_M3_8

6 The Part family Component is created and contains as many components as the number of rows in the Design Table of the Part.

If the part number is not resolved, the description of each component will refer to the same .CATPart File

Part Family Resolution (1/2)

You can choose to generate all files corresponding to components of your PartFamily in a storage folder.

Unresolved: Part Family Components refer to the same single CATPart file which is driven by a Design Table

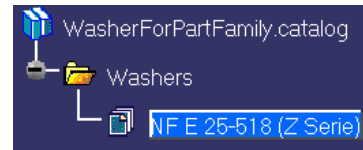

Resolved: each component refers to its proper CATPart File which has no external Link

Reference	Keywords	Preview	Generative Data	
d	e	D	PartNumber	
1	6mm	2mm	12mm	ThickWasher_Z6
2	8mm	3mm	16mm	ThickWasher_Z8
3	10mm	3mm	20mm	ThickWasher_Z10
4	12mm	3.5mm	24mm	ThickWasher_Z12
5	14mm	4mm	30mm	ThickWasher_Z14
6	16mm	4.5mm	32mm	ThickWasher_Z16
7	20mm	5mm	40mm	ThickWasher_Z20

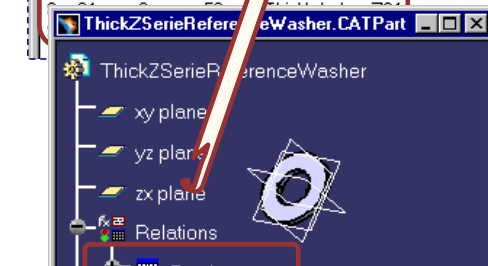

1				
2	6	2	12	ThickWasher_Z6
3	8	3	16	ThickWasher_Z8
4	10	3	20	ThickWasher_Z10
5	12	3.5	24	ThickWasher_Z12
6	14	4	30	ThickWasher_Z14
7	16	4.5	32	ThickWasher_Z16
8	20	5	40	ThickWasher_Z20
9	24	6	50	ThickWasher_Z24
10	30	7	60	ThickWasher_Z30

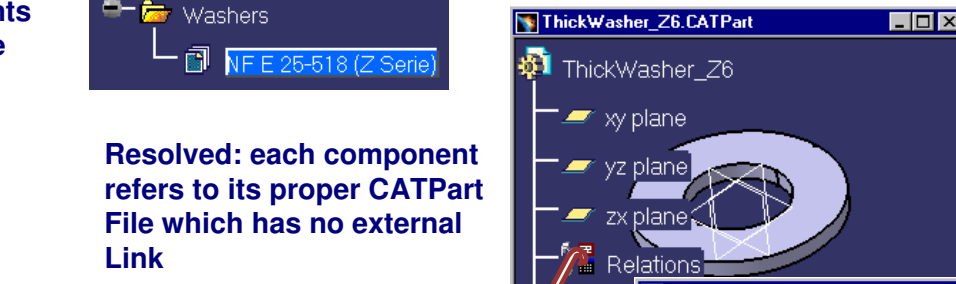

Reference	Keywords	Preview	Generative Data	
d	e	D	PartNumber	
1	6mm	2mm	12mm	ThickWasher_Z6
2	8mm	3mm	16mm	ThickWasher_Z8
3	10mm	3mm	20mm	ThickWasher_Z10
4	12mm	3.5mm	24mm	ThickWasher_Z12
5	14mm	4mm	30mm	ThickWasher_Z14
6	16mm	4.5mm	32mm	ThickWasher_Z16
7	20mm	5mm	40mm	ThickWasher_Z20
8	24mm	6mm	50mm	ThickWasher_Z24
9	30mm	7mm	60mm	ThickWasher_Z30

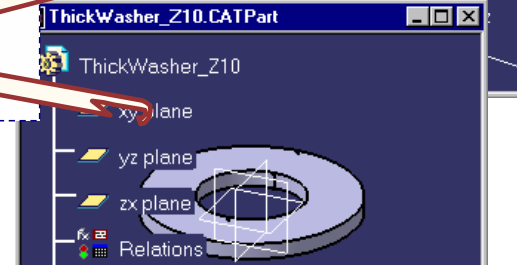

Part Family Resolution (2/2)

Whole PartFamily resolution

Result				
Reference	Keywords	Preview	Generative Data	
	d	e	D	PartNumber
1	6mm	2mm	12mm	ThickWasher_Z6
2	8mm	3mm	16mm	ThickWasher_Z8
3	10mm	3mm	20mm	ThickWasher_Z10
4	12mm	3.5mm	24mm	ThickWasher_Z12
5	14mm			
6	16mm			
7	20mm			
8	24mm			
9	30mm			

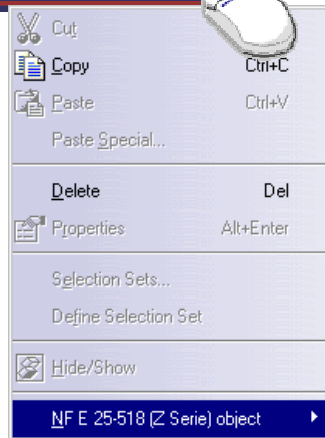
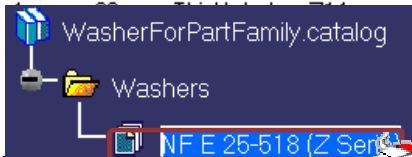

Single PartFamily Component resolution

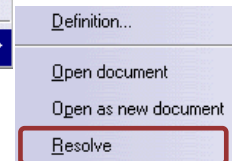
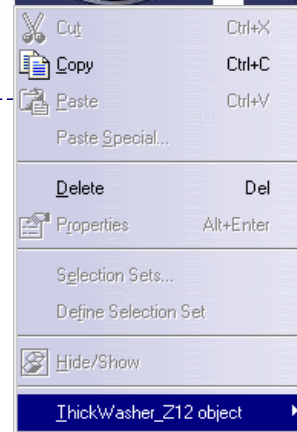
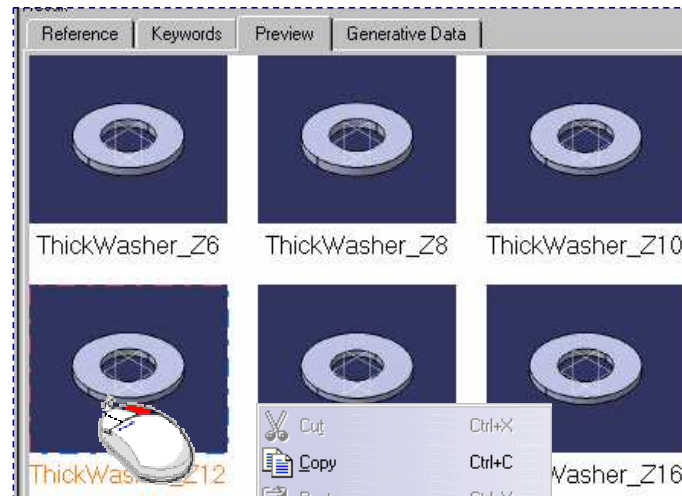

Path of Storage Folder is a Setting:

Resolved Family Components
Storage Folder: E:\AAFamily

Referencing Data from External Catalogs

You will learn how to create references to chapters of other catalogs and to create sets of components that are the result of a query on an external catalog.



Student Notes:

Adding a Link to Another Catalog (1/2)

If the Chapter you want to create already exists in another catalog, this capability will allow you to add a link to this chapter from the current catalog

- 1 Open the catalog for which you want to add a link to an external chapter(File > Open)

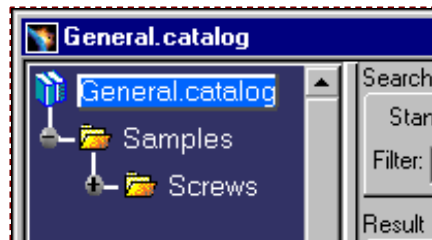

- 2 Open the catalog from which you want to get the chapter (File > Open)

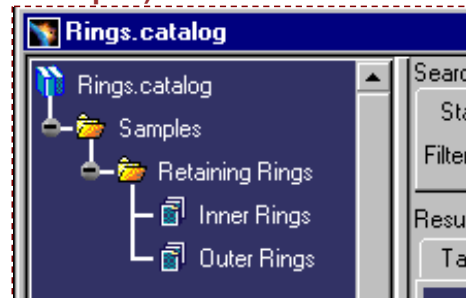

- 3 Activate the chapter under which you want to add the link.



Adding a Link to Another Catalog (2/2)

If the Chapter you want to create already exists in another catalog, this capability will allow you to add a link to this chapter from the current catalog

- 4 Click the “Link to other catalog” icon



- 5 Select the chapter or family to import

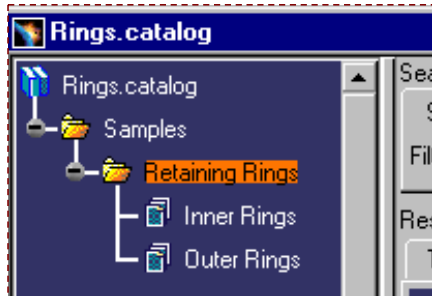

A new chapter appears in the receiving Catalog.

A link has been created

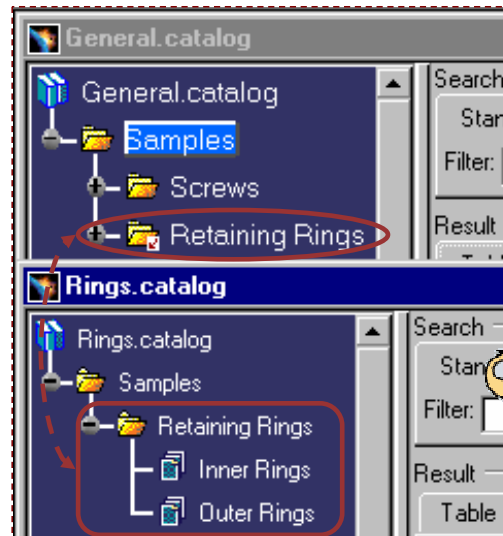

When a family or a chapter comes from another catalog it is indicated in the tree.

Family from another catalog

Chapter from another catalog

If you want to know precisely where it comes from, use the Edit>Links command

If you change anything in the linked chapter it will be changed in both catalogs

What are Catalog Filter Resolved Components

You can create lists of components that are result of filter applied on components of an external catalog. Those lists are Catalog Filter resolved Components.

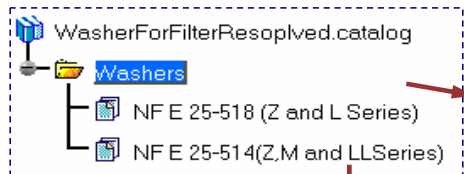

Reference	Keywords	Preview	Generative Data	
d	e	D	PartNumber	
1	6mm	2mm	12mm	ThickWasher_Z6
2	8mm	3mm	16mm	ThickWasher_Z8
3	10mm	3mm	20mm	ThickWasher_Z10
4	12mm	3.5mm	24mm	ThickWasher_Z12
5	14mm	4mm	30mm	ThickWasher_Z14
6	16mm	4.5mm	32mm	ThickWasher_Z16
7	20mm	5mm	40mm	ThickWasher_Z20
8	24mm	6mm	50mm	ThickWasher_Z24
9	30mm	7mm	60mm	ThickWasher_Z30
10	6mm	3mm	16mm	ThickWasher_L6
11	8mm	4mm	22mm	ThickWasher_L8
12	10mm	4mm	27mm	ThickWasher_L10
13	12mm	5mm	32mm	ThickWasher_L12
14	14mm	5mm	40mm	ThickWasher_L14
15	16mm	6mm	45mm	ThickWasher_L16
16	20mm	6mm	55mm	ThickWasher_L20
17	24mm	7mm	65mm	ThickWasher_L24

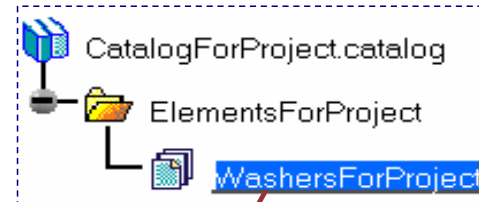

Reference	Keywords	Preview	Generative Data	
d	e	D	PartNumber	
1	1.6mm	0.5mm	3.5mm	Washer_Z1.6
2	2mm	0.5mm	4mm	Washer_Z2
3	2.5mm	0.5mm	5mm	Washer_Z2.5
4	3mm	0.8mm	6mm	Washer_Z3
5	4mm	0.8mm	8mm	Washer_Z4
6	5mm	1mm	10mm	Washer_Z5
7	6mm	1.2mm	12mm	Washer_Z6
8	8mm	1.5mm	16mm	Washer_Z8
9	10mm	2mm	20mm	Washer_Z10
10	12mm	2.5mm	24mm	Washer_Z12
11	14mm	2.5mm	27mm	Washer_Z14
12	16mm	3mm	30mm	Washer_Z16
13	18mm	3mm	36mm	Washer_Z18
14	20mm	3mm	40mm	Washer_Z20
15	24mm	3.5mm	48mm	Washer_Z24
16	28mm	4mm	56mm	Washer_Z28
17	32mm	4mm	64mm	Washer_Z32
18	36mm	4.5mm	72mm	Washer_Z36
19	40mm	5mm	80mm	Washer_Z40
20	45mm	5mm	90mm	Washer_Z45
21	5mm	1mm	12mm	Washer_M5
22	6mm	1.2mm	14mm	Washer_M6
23	8mm	1.5mm	18mm	Washer_M8
24	10mm	2mm	22mm	Washer_M10
25	12mm	2.5mm	27mm	Washer_M12
26	14mm	2.5mm	30mm	Washer_M14
27	16mm	3mm	36mm	Washer_M16
28	18mm	3mm	40mm	Washer_M18
29	20mm	3mm	45mm	Washer_M20
30	24mm	4mm	54mm	Washer_M24
31	28mm	4mm	60mm	Washer_M28
32	32mm	4mm	68mm	Washer_M32
33	36mm	4.5mm	76mm	Washer_M36
34	40mm	5mm	84mm	Washer_M40
35	45mm	5mm	94mm	Washer_M45
36	8mm	1.5mm	30mm	Washer_LL8
37	10mm	2mm	36mm	Washer_LL10
38	12mm	2.5mm	40mm	Washer_LL12
39	14mm	2.5mm	45mm	Washer_LL14
40	16mm	3mm	50mm	Washer_LL16
41	20mm	3mm	60mm	Washer_LL20
42	24mm	4mm	70mm	Washer_LL24
43	30mm	4mm	80mm	Washer_LL30
44	36mm	5mm	90mm	Washer_LL36

External Catalog

Result of a query on all components of the external catalog

Reference	Keywords	Preview	Generative Data
Name			
1	ThickWasher_Z8		
2	ThickWasher_Z10		
3	ThickWasher_Z12		
4	ThickWasher_L8		
5	ThickWasher_L10		
6	ThickWasher_L12		
7	Washer_Z8		
8	Washer_Z10		
9	Washer_Z12		
10	Washer_M8		
11	Washer_M10		
12	Washer_M12		
13	Washer_LL8		
14	Washer_LL10		
15	Washer_LL12		

Student Notes:

Catalog Filter Resolved Components (1/2)

You first need to select the external catalog and define your query.

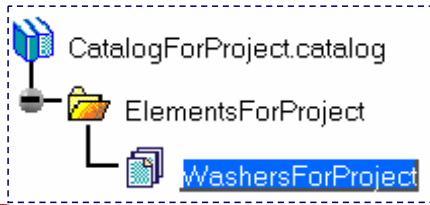

1 Activate the Family



2 Select the command

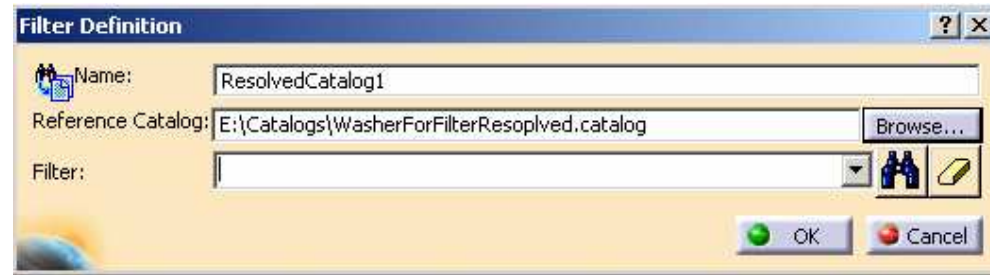

3 Select the external catalog

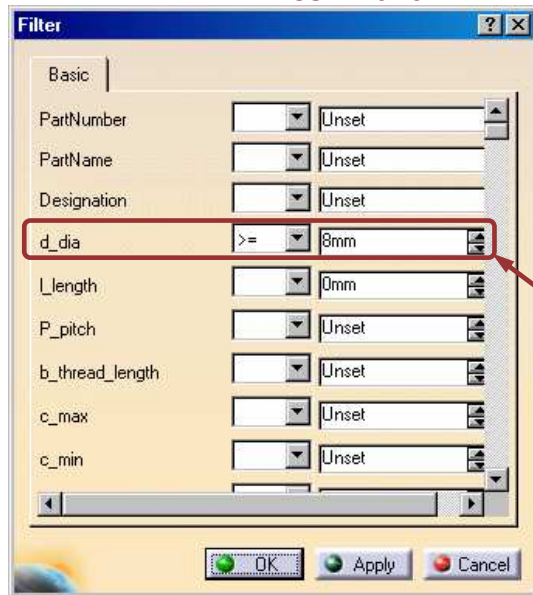

4 Define your query

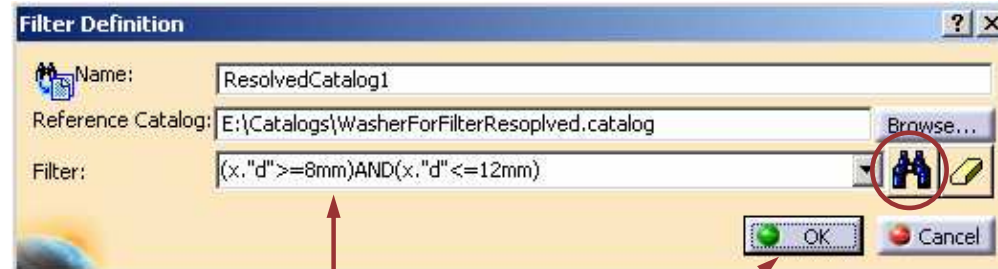

5 Validate

Catalog Filter Resolved Components (2/2)

Next step consists in making resulting components of the query available by resolving the query.

6 Select Generative Data tab

7 Double click the query

8 Click on 'Apply Filter' button.

9 Click on OK

Resolved Query

Generated components of selected query

Components generated from a query are referenced as external description

Name	Date(D-M-Y)	Definition	Status
1 Query1	16-5-2001	(d>=8mm) AND (d<=12mm)	Resolved

Name	Type	Object Name
1 ThickWasher_Z8	External description	E:\ResolvedFilterCatalog\WasherForFilterResoplvded.catalog
2 ThickWasher_Z10	External description	E:\ResolvedFilterCatalog\WasherForFilterResoplvded.catalog
3 ThickWasher_Z12	External description	E:\ResolvedFilterCatalog\WasherForFilterResoplvded.catalog
4 ThickWasher_L8	External description	E:\ResolvedFilterCatalog\WasherForFilterResoplvded.catalog
5 ThickWasher_L10	External description	E:\ResolvedFilterCatalog\WasherForFilterResoplvded.catalog
6 ThickWasher_L12	External description	E:\ResolvedFilterCatalog\WasherForFilterResoplvded.catalog
7 Washer_Z8	External description	E:\ResolvedFilterCatalog\WasherForFilterResoplvded.catalog
8 Washer_Z10	External description	E:\ResolvedFilterCatalog\WasherForFilterResoplvded.catalog
9 Washer_Z12	External description	E:\ResolvedFilterCatalog\WasherForFilterResoplvded.catalog

Checking the Catalog Preview

You will learn how to preview catalog files.

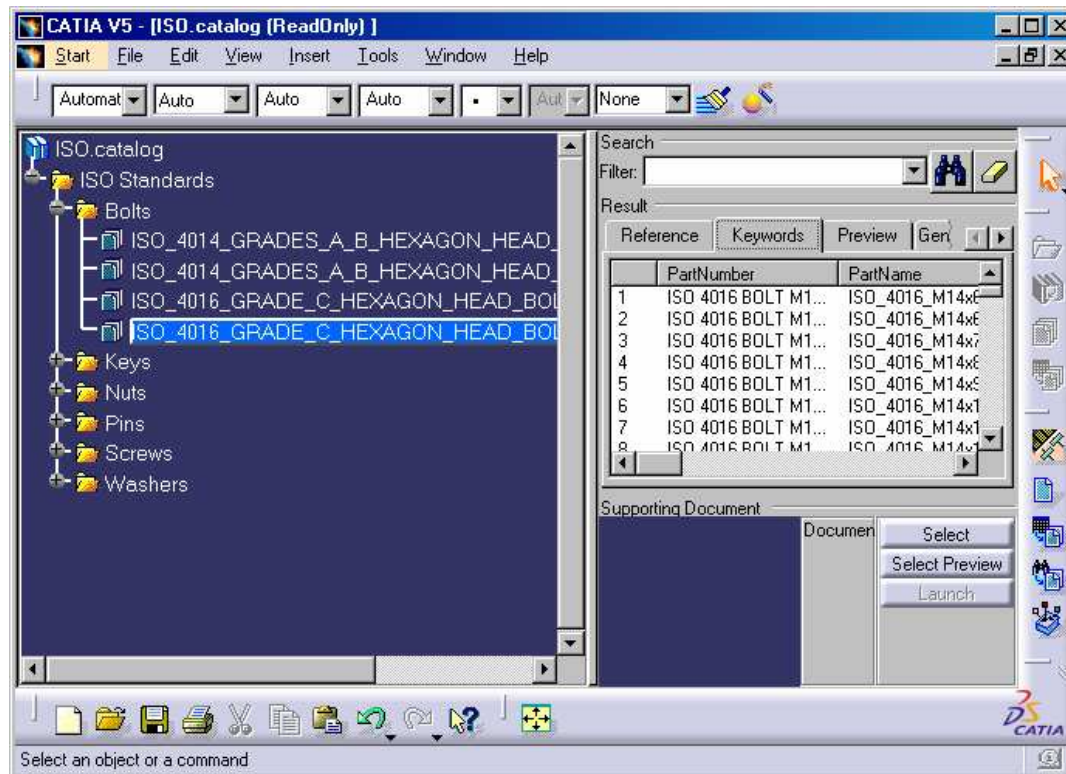

A catalog

What is Catalog Preview

You will not have the same view of a Catalog whether you open it with the Catalog Editor or with the Catalog Browser.

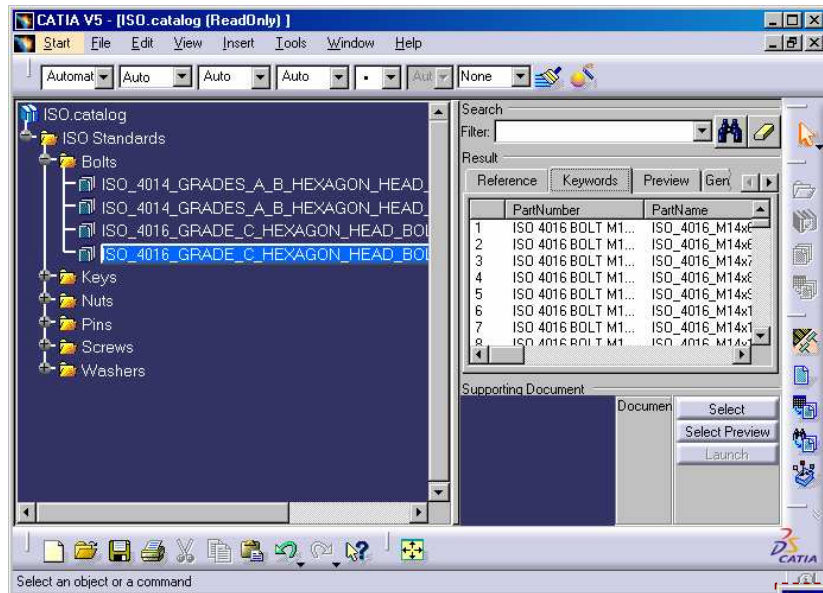

Catalog Editor

Browser icon is available in the Catalog Editor workbench in order to browse the Catalog currently edited. Let us have a look at the differences between the views.

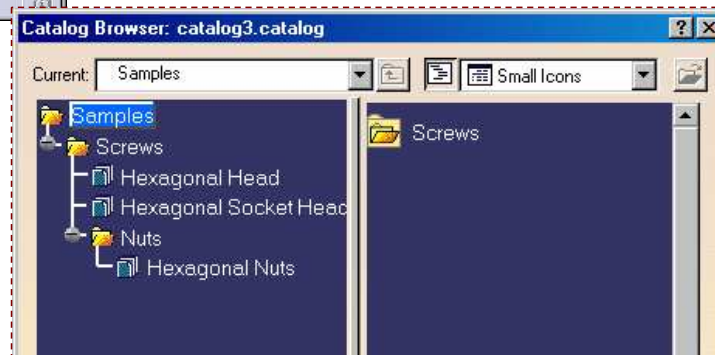





Catalog Browser

Catalog Preview (1/2)

View from the Catalog Editor...

You have a global view of the structure of your catalog

Structure tree of the catalog indicates if the feature is :
 a Catalog 
 a Chapter 
 a family 
 if the feature comes from another catalog 

The Table tab displays all the contents of the active Chapter or Family

To get a Chapter or a Family active, just double click on it

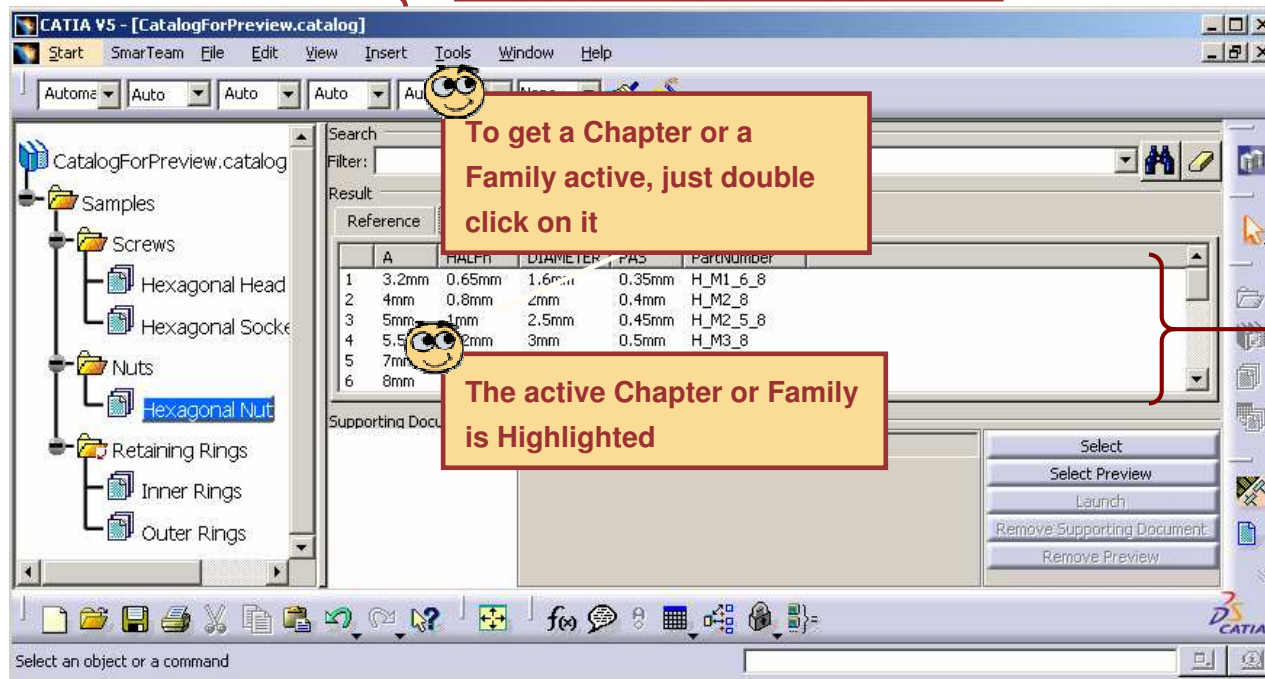

The active Chapter or Family is Highlighted



Catalog Preview (2/2)

View from the Catalog Browser...

You can load the currently edited Catalog by clicking on this icon 

The folder icon behind the main icon indicates that there is a content.  Content can be Chapters , Families or Components. When you do not have folder icon behind the main icon  , it means that there is not content and that it is a Component

To see the content of an element, just double click on it 

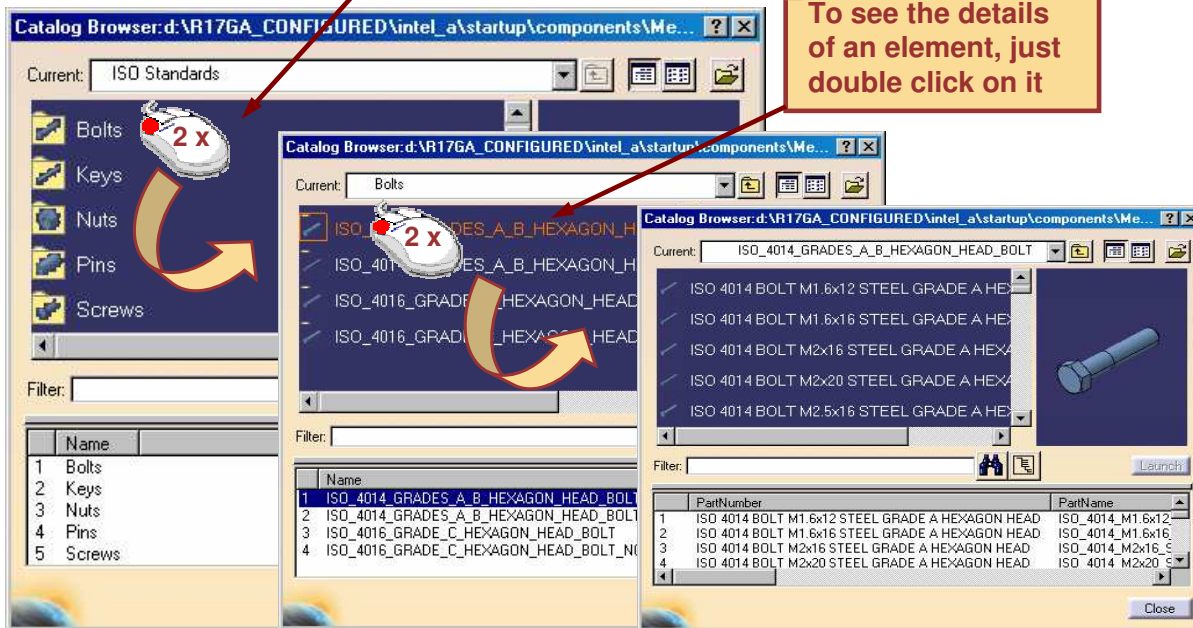

Keywords Visibility

You can control the visibility of a keyword in the browser.

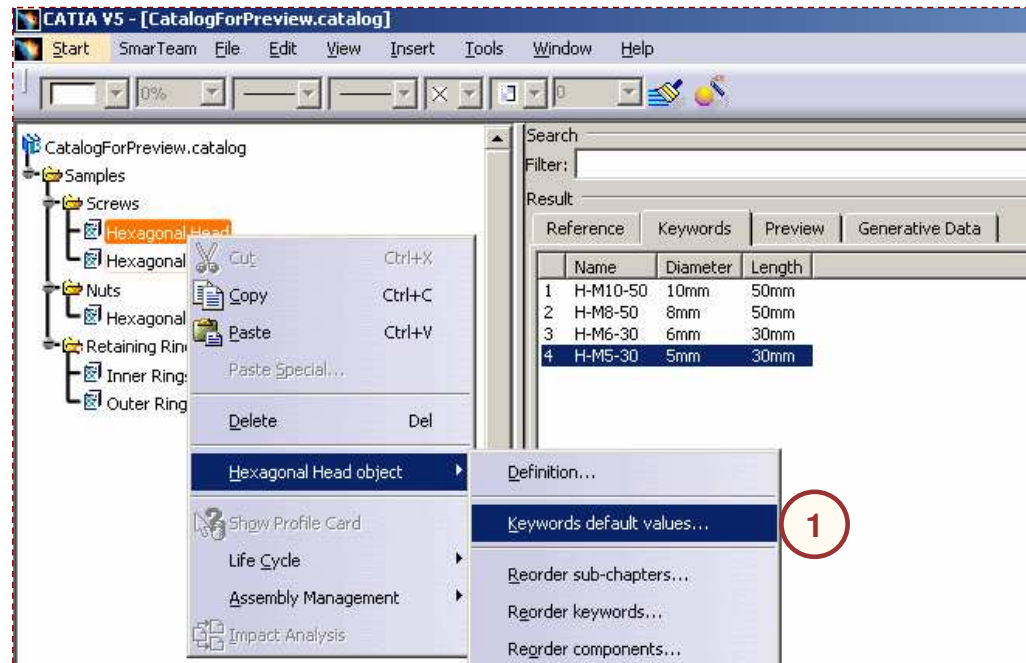

In contextual menu of the family, select “Keywords Default values”

Keywords Visibility

Select the keyword

2



Deactivate this option

Click on OK

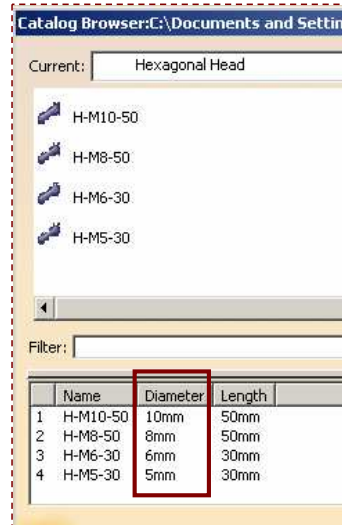

You will hide the Part number in the display

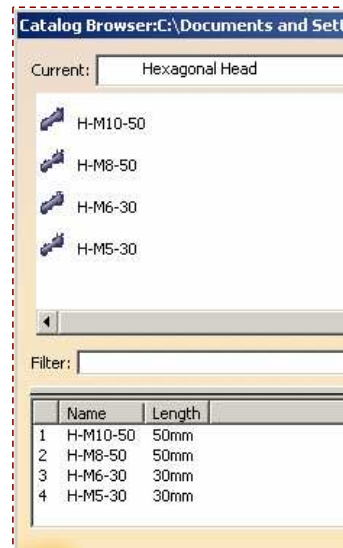
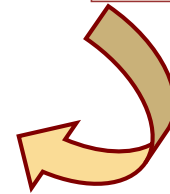

Creating Catalogs in Batch Mode

You will learn how to create catalogs in batch mode using Text or Excel files and macros.



	A	B	C	D
1	CHAPTER	Samples	envelope	
2	Keywords	type		
3	Types	String		
4		screw	screws2.catalog	
5		box	boxes2.catalog	
6				

Definition file

What is Behind Catalogs ?



■ **Catalog files generated after running a macro**



■ **CATIA documents (parts or assemblies) referenced in catalogs**

■ **Macro scripts used to generate catalogs**

■ **Text or Excel files (.csv format) used to create & define, and modify catalog content**

■ **Reports generated by macros**

Sample source files

Name	Size	Type
boxes2.catalog	21KB	CATALOG File
chapter2.catalog	20KB	CATALOG File
screws2.catalog	24KB	CATALOG File
boite_100x200x300.CATPart	85KB	CATIA Part
boite_200x300x400.CATPart	87KB	CATIA Part
box_100x200x300.CATPart	85KB	CATIA Part
box_200x300x400.CATPart	87KB	CATIA Part
CBL-Z-M4-16.CATPart	281KB	CATIA Part
CBL-Z-M4-20.CATPart	303KB	CATIA Part
CHC-M4-16.CATPart	105KB	CATIA Part
CHC-M4-20.CATPart	111KB	CATIA Part
CZX-M4-16.CATPart	392KB	CATIA Part
CZX-M4-20.CATPart	388KB	CATIA Part
boiteavecvis.CATProduct	18KB	CATIA Product
boxes-creation2.CATScript	1KB	CATIA Script
chapter_creation2.CATScript	1KB	CATIA Script
screws-creation2.CATScript	1KB	CATIA Script
boxes2.csv	1KB	Fichier texte (s...
chapter2.csv	1KB	Fichier texte (s...
screws2.csv	1KB	Fichier texte (s...
boxes2.report	1KB	REPORT File
chapter2.report	1KB	REPORT File
screws2.report	1KB	REPORT File



Catalogs can be stored with parts they reference. Otherwise, the Search Order must be correctly set

Student Notes:

How Does it Work ?

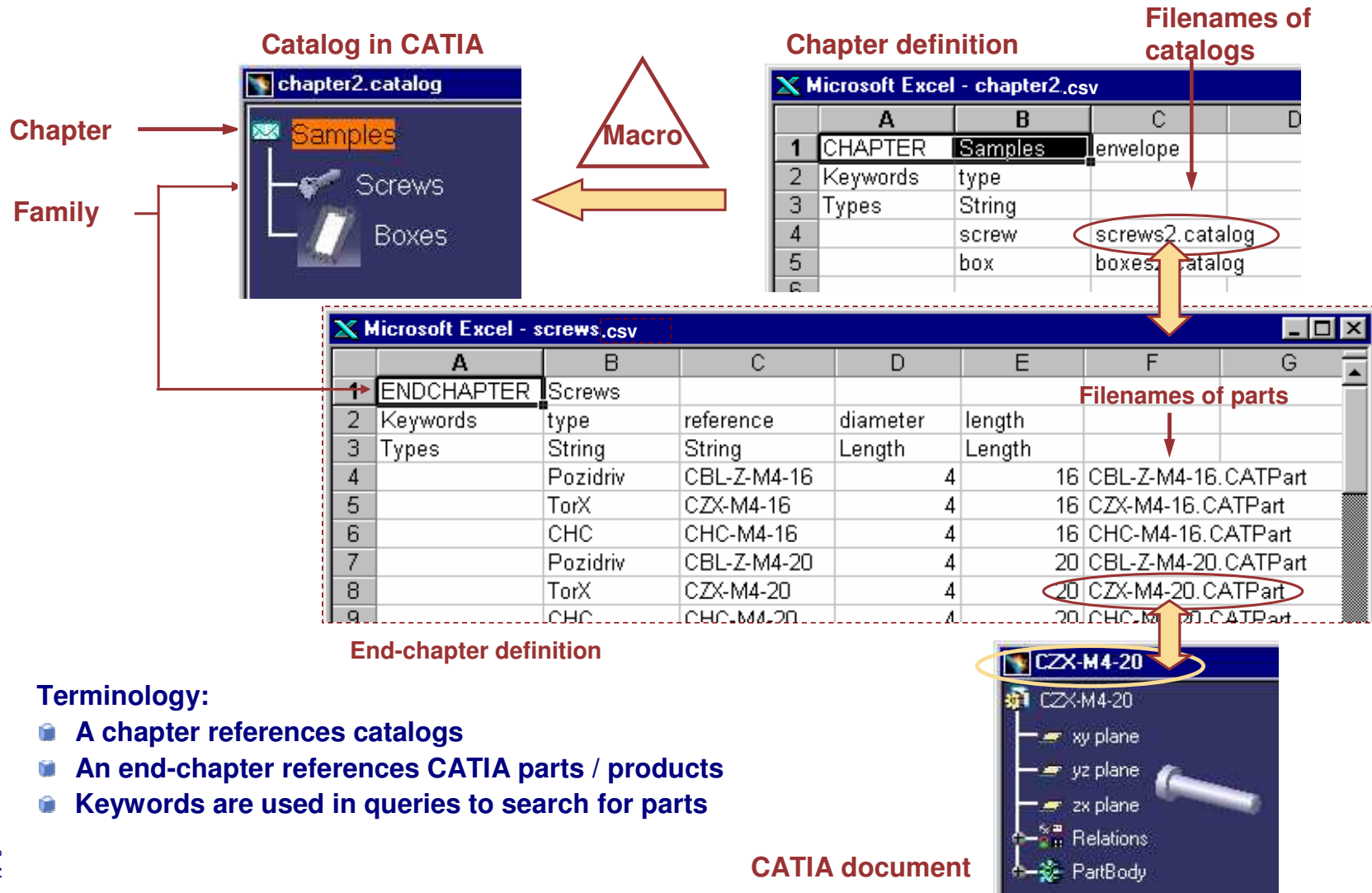

Creating Catalogs in Batch Mode

When you create catalogs of parts, you define chapters and families (see example below)

	A	B	C	D
1	CHAPTER	Samples	envelope	
2	Keywords	type		
3	Types	String		
4		screw	screws2.catalog	
5		box	boxes2.catalog	

- 1 Edit csv files: define chapters and families, keywords, names of referenced catalogs or parts & products, and component characteristics (Knowledgware syntax)



You can customize a catalog icon by entering the location and name of the image to be used in cell C1 of the table

	A	B	C	D	E	F	G
1	ENDCHAPTER	Screws	E:\users\jmy\CATALOGVIS\Images\screw.bmp				
2	Keywords	type	reference	diameter	length		
3	Types	String	String	Length	Length	*	
4		Pozidriv	CBL-Z-M4-16	4	16	CBL-Z-M4-16.CATPart	
5		TorX	CZX-M4-16	4	16	CZX-M4-16.CATPart	
6		CHC	CHC-M4-16	4	16	CHC-M4-16.CATPart	

Note that you can define absolute location of catalogs and parts

- 2 Save the files as .csv (usable on UNIX)
- 3 CATIA settings: reference (if not already done) the CclTypeLib library from intel_a\code\bin using Tools > Options > General > Automation > Add
- 4 Edit macro BuildCatalog.CATScript (input & output catalog names & location) & Run it



You can have one macro per catalog. Then, you do not need to edit the macro each time (input / output names already defined)

- 5 You can check the report resulting from the catalog creation

Define the absolute path of the input csv file
`csvFile = "...\Online\Samples\Infrastructure\chapter2.csv"`
 Define the absolute path of the output catalog file
`catalogFile = "...\chapter2.catalog"`

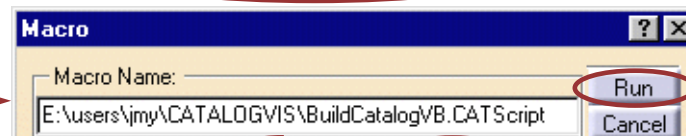

Creating chapter2.catalog
 From chapter2.csv

 Batch successfully ended

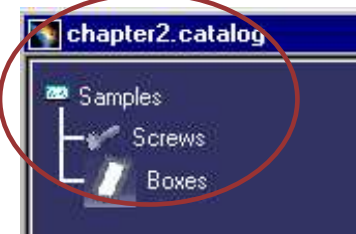

To Sum Up ...

You have learned how to:

- **Create Catalog.** You can create empty Catalog, CATPart containing Power copies as Catalog, CATDrawing containing detail sheets and dittos as Catalog
- **Create Chapters.** A Chapter is a set of references. It will refer to other Chapters or Families.
- **Create Families.** A Family is a set of references. It refers components that can be CATIA documents (CATPart or CATProduct) or CATIA features (Details or Power copies).
- **Create Keywords.** Keyword allows you to characterize references in a Chapter or Family. Values of Keywords will help you sort them out when searching for an object.
- **Create Components.** A Component is a reference to an external document or feature. The components keyword values are displayed.
- **Reference data from external Catalogs.** Create references to chapters of other catalogs and to create sets of components that are the result of a query on an external Catalog.
- **Create Catalogs in Batch mode.** Creating Catalogs in batch mode using text or excel files and macros.

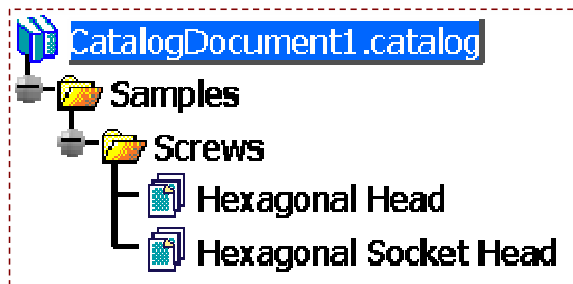

From CATIA V4 to V5 Basics

You will learn how to read a simple CATIA V4 model and copy it into a V5 document, and to manage your visualization using layers and filters

Working with a CATIA V4 Document

Working with a CATIA V4 Document

You will learn how to copy CATIA V4 data in CATIA V5



V4 model loaded in CATIA V5

Student Notes:

About CATIA V4 and CATIA V5 Analogy

Data	V4 Files	V5 Files
Solid, Surface and Wireframe	.Model	.CATPart
Drawing	.Model	.CATDrawing
Part Positioning	.session, .asm, ditto	.CATProduct
Library	.lib	.Catalog

User Interface: CATIA V4,V3,V2 Workbench

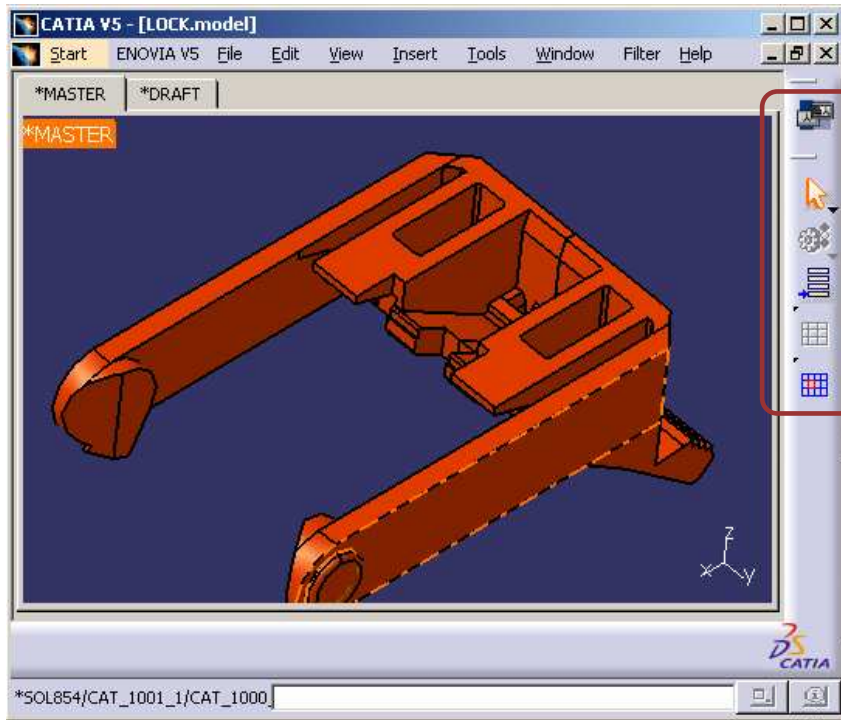

V4 Integration workbench

Check Tools



Using the Check Tools



Geometry Check : Check by transferring the solid's geometry through Copy-Paste Special as CATIA_Result



Geometry Specification : Check by transferring the solid with geometry and the history tree through Copy-Paste Special as CATIA_Spec

About Copy and Paste Options

Using the Paste Special Tools

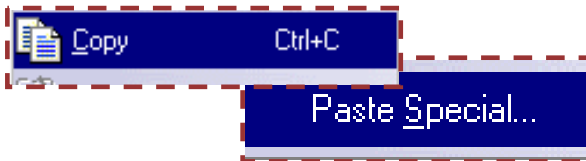

- **CATIA_RESULT:** the result is a Boundary Representation feature i.e. Brep feature
 - ◆ **Example:** V4 surface becomes a surface in an Open Body & V4 solid becomes a Solid in a Part Body

- **CATIA_SPEC:** the result is a full Spec containing entire history of the actions performed to obtain the V5 Part.
 - ◆ **Note :** you can modify the features in the history tree

What are the Different Methods ?

In CATIA V5 you can read a V4 model, check its content, and manipulate the geometry, but not save it directly. First, you need **copy** it into a V5 document.

There are two methods:

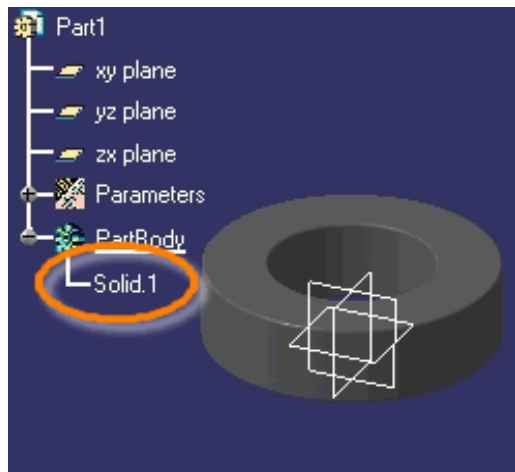

Copy without history

- A** A simple copy generates a Solid object which cannot be modified but can be used as reference

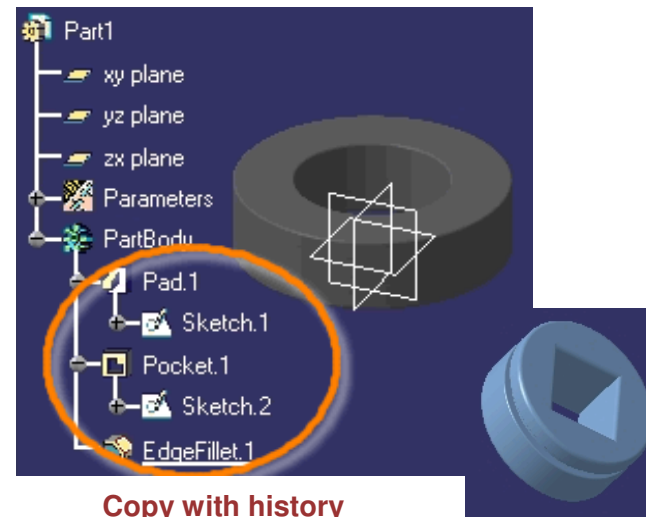

Copy with history

- B** A special copy takes into account the V4 specifications and generates V5 features. You can edit the part body as well as the features (as shown on right picture)

Student Notes:

General Process

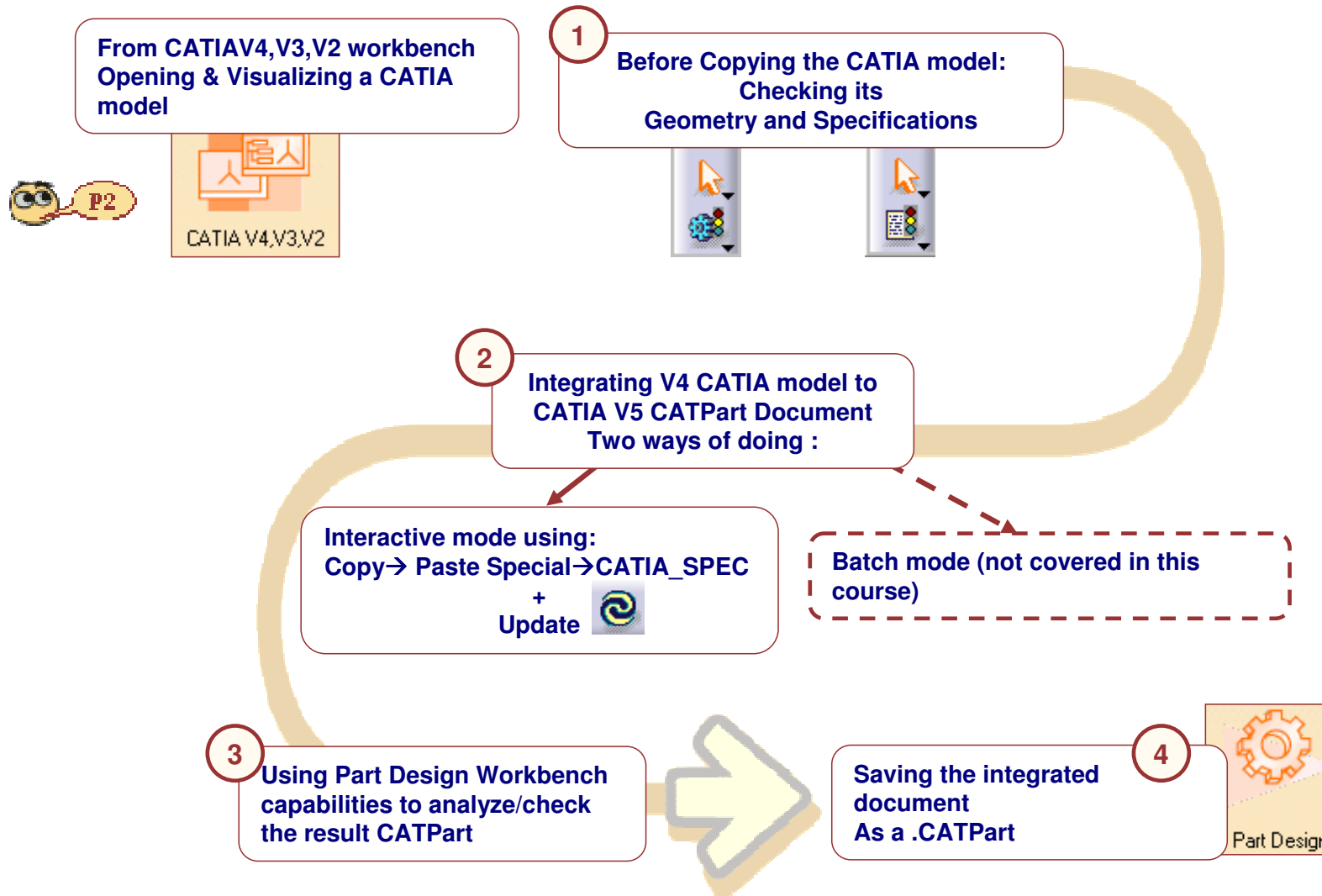

Checking CATIA V4 Model Data before Copying it to CATIA V5 Document (1/2)

You need to check either the geometry or the specification of CATIA V4 model data

- 1 Open the CATIA V4 model and select one or more geometrical elements in the geometry area

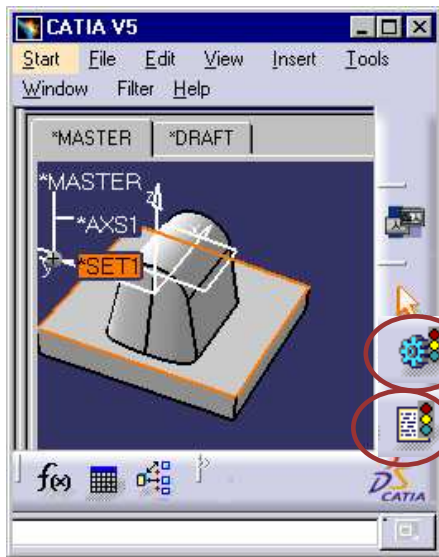

CATIA V4 Integration workbench & toolbar

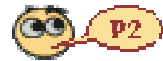

- 2 Click Geometry Check icon

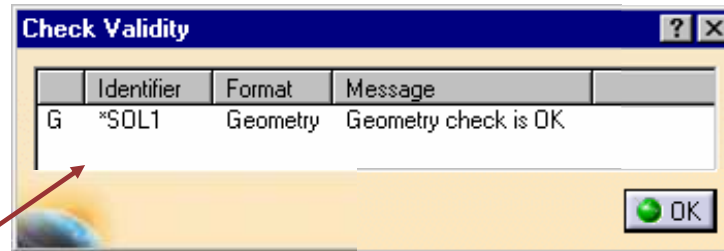

The Check Validity dialog box appears



You can transfer the solid's geometry only through copy - paste special - As a Result.

- 3 Click Specifications Check icon. The Check Validity dialog box appears

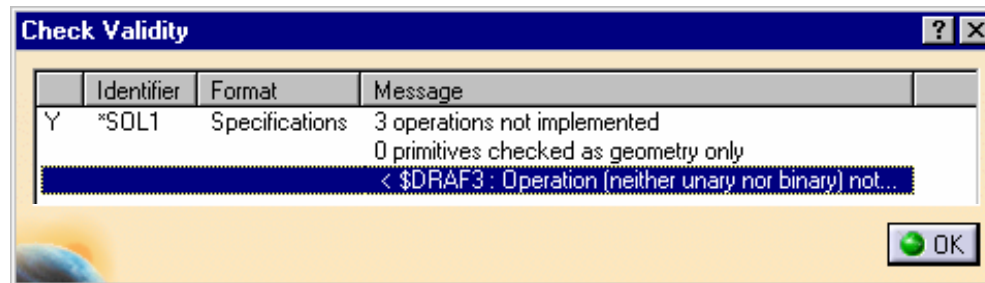

"3 operations not implemented" : 3 operations will be unavailable in a migration to CATIA V5.

Checking CATIA V4 Model Data before Copying it to CATIA V5 Document (2/2) P2

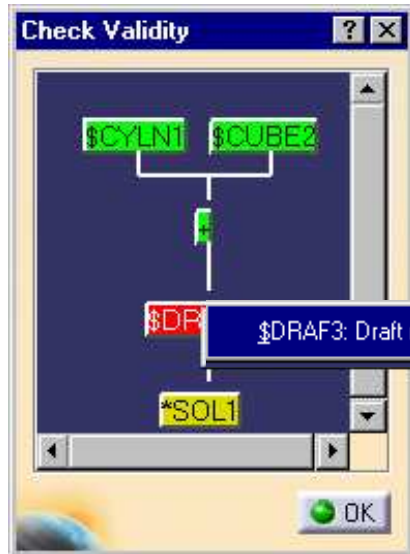

4 To view the results of a specification check, double-click on the contents of the selected line in the Check Validity dialog box.

5 Right-click the red element to discover the problem

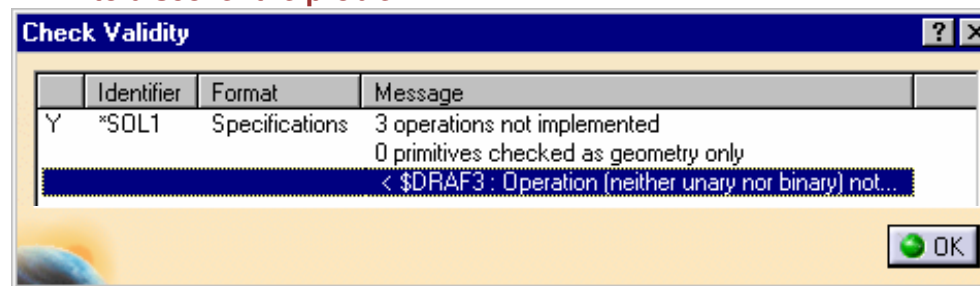

 The \$ symbol means that the Pipe item is an unresolved feature in V5 (same symbol in the V4 tree).

 In the Check Validity dialog box there are four columns:

- The first column showing the overall result, color-coded as follows:
 - G (green):** will be copied as is to CATIA Version 5. The check is OK.
 - R (red):** will NOT be copied to CATIA Version 5 as is. This is a KO Check.
 - Y (yellow):** will NOT be copied to CATIA Version 5 as is because of a link to a red-coded item. This is KO Check due to the element supporting by the solid.
- CATIA identifies the identifier & the format i.e. Specifications
- The Message column provides the number and type of problems.

Student Notes:

Copying a CATIA V4 Solid into CATIA V5

1 File > Open

P2

V4 Workspaces

2 Double click MASTER to see its content



V4 Integration workbench & tools

Select mode
Geometry check

3 Open a (new) V5 document

4 Click V4 geometry (if simple part) or the desired object in the tree, then Copy (Edit menu or MB3)

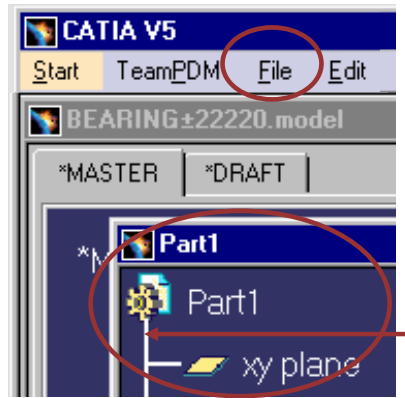

5 Click in V5 tree, then Paste Special (Edit menu or MB3)

6 Click CATIA SPECS then OK to keep the V4 model history

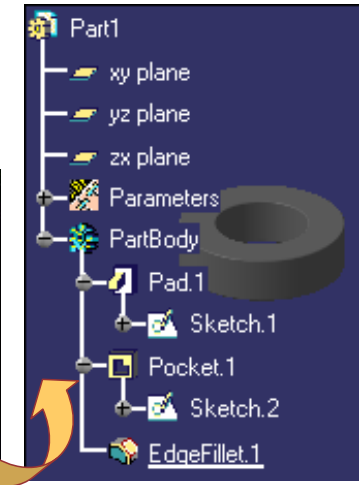

Resulting tree.

Edit > Update the geometry to visualize it

7

To Sum Up ...

You have learned how to:

- Draw analogy between CATIA V4 and V5 data.



- Manage CATIA V4 Documents with CATIA V5 using copy paste options.

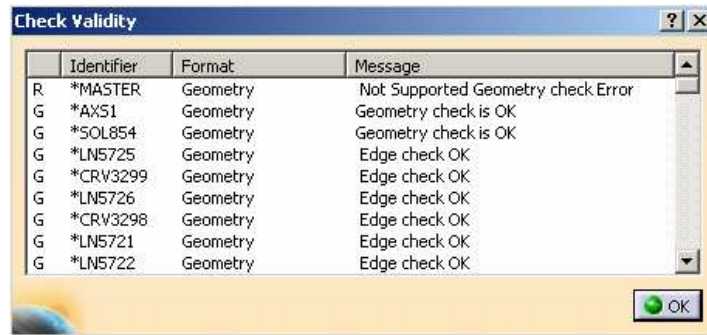

- Check CATIA V4 data before copying it to CATIA V5 data.

Course Summary

You have seen some advanced functionalities of CATIA V5 such as :

- **Creating and Using Power copies**
- **Creating Catalogs of Components**
- **Working with documents from CATIA V4 to V5**